

ALIEN SECRETS

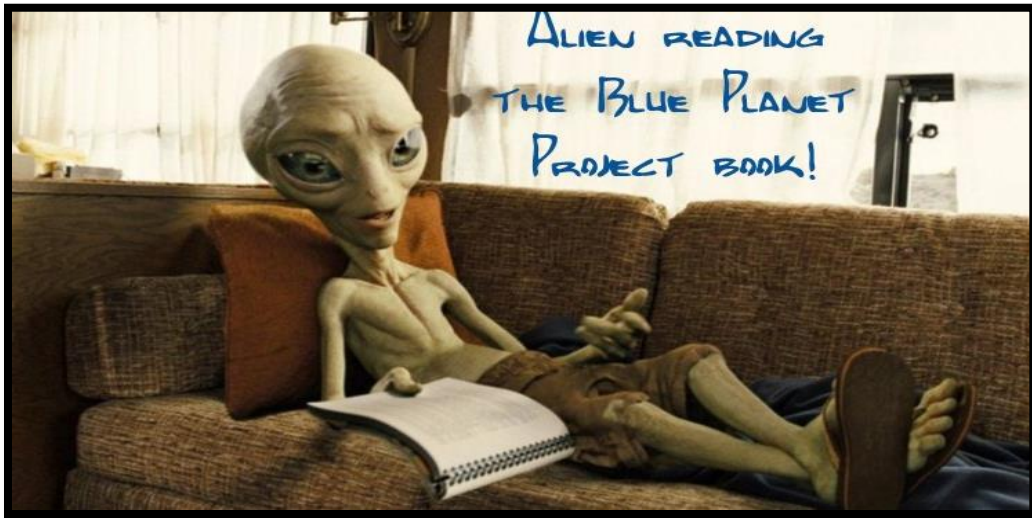

By Gil Carlson

ISBN: 13: 978-1-63535-853-7

(C) Copyright 2017 Gil Carlson

Blue Planet Press

Contact us at: BluePlanetPress@aol.com

To discover the rest of the books in this Blue Planet Project Series:

www.blue-planet-project.com/



The material in this book has not been submitted to or approved by any U.S. intelligence agency. If anything is discovered that is considered by your agency to be classified, notify the publisher.

Why is this book important?

Here is a book crammed full of secrets, alien secrets from some of the world's top experts. But these are still secrets, because the funny thing is that they have been hidden from us. That is until now!

Why is it that when a scientist or other expert is famous for their findings in the scientific community and everything they communicate becomes widely spread, then it all changes when aliens and UFOs are mentioned? It then becomes a “hot-potato” and no one will touch it? I guess that's a silly question because we all know the answer. The fear of ridicule by their peers or prosecution (direct or indirect) by the government takes its toll.

Now I'm going to bring to you all these alien and UFO secrets I've just discovered! Sure, the government won't be too happy with me when they get wind of this new book, but that's nothing new, we've been at odds for years.

GIL CARLSON

Here's What's Inside:

Colonel Philip Corso.....	3
Dr. Michael Wolf.....	20
Nikola Tesla – Aliens – UFOs - StarWars.....	34
Dr. T. Townsend.....	61
B2 Controls Gravity.....	68
Art Bell's Mystery Metal.....	71
Senator Richard B. Russell Jr. - UFO Sighting..	86
Alec Newald Reveals Info From Aliens.....	90
Researcher David Jacobs on Aliens.....	105
Dr. Richard Bonenfant - Bigfoot, UFO.....	109
Do You Have Alien Blood?.....	115
Ex-CIA Official - Crashed UFOs.....	121
Additional Experts Reveal Alien Truth's.....	126

Colonel Phillip Corso

This is one of the most prominent names in recent history, the author of the book, "The Day After Roswell", revealed the secrets of the back-engineering of alien artifacts by the military utilizing the program that he created. I personally, have felt the Philip was one of the sincere and believable authors in this field.



In his book "The Day After Roswell", he covered such alien technologies as super-tenacity fibers, the carbon fibers that were back-engineered to create items such as Kevlar.

They produced the integrated circuit, another alien technology, and Philip held the very first one in his hand. Bell Laboratories went, overnight, from the transistor, which was an earth invention, to all of a sudden having

thousands of transistors on a little tiny chip so small that you really could hardly even see it. A chip is about so big, with all the little legs on it, as you probably know, black, and plugs in. But the actual electronic part is a dot in the middle, and it's too small to handle so they put it in this case about 20 times larger, where at least a machine can handle it and plug it in.

American Computers, which was formerly Westinghouse, had just invented the miniature test tube and soon found themselves out of the electronics business.

200 years advanced due to alien technology? That's what my Philip Corso and General Trudeau estimated where we are right now. We're 200 years ahead of where we should be.

Fiber optics was another one of these alien technologies that we were able to use. When discovered in a crashed UFO (probably from Roswell), instead of wires, they discovered these tubes and it took a while to discover how they were used, although we may not have discovered the complete secret yet. When Corso held that tube from the UFO with his hand around it, it began to glow! So, it has something to do with the biology of the body. A secret we still haven't cracked yet!



Our night viewing technology came from the aliens. Originally it was a lens on the eyes of a Grey Alien that peels off, and then he has two more lids underneath. The Grey has the eyeball and then another protective lid such as like a shark has. Corso, would hold it up to his eye and he saw green images of people walking in the backgrounds and such.

While us humans were already working on lasers, they did not compare to the alien artifacts, which then spurred a whole new world of miniaturized and more powerful lasers.

While Philip Corso's integrity is beyond reproach and his claims and his military record has withstood many investigations, "The Day After Roswell" may be a different matter. From what I've seen, I believe that the basic information and intention of his book is accurate, some new information has come out.

Corso's son claims that his father didn't get a chance to proofread the book as it was rushed into production very quickly, and he was very upset about how it turned out. As Corso was an extremely meticulous person, he probably couldn't handle any of the normal changes usually made to books to make them more readable. It was claimed that his book was "Hollywood-ized"

NOW FROM PHILIP CORSO'S DIARY, NOTES AND OTHER WRITINGS:

Read on and you too will be will be wondering why this material hasn't been made readily available before now.

CORSO MEETS ALIENS:

in 1957 Colonel Philip J. Corso had a face-to-face encounter and a telepathic conversation with an Extraterrestrial Biological Entity (EBE) while

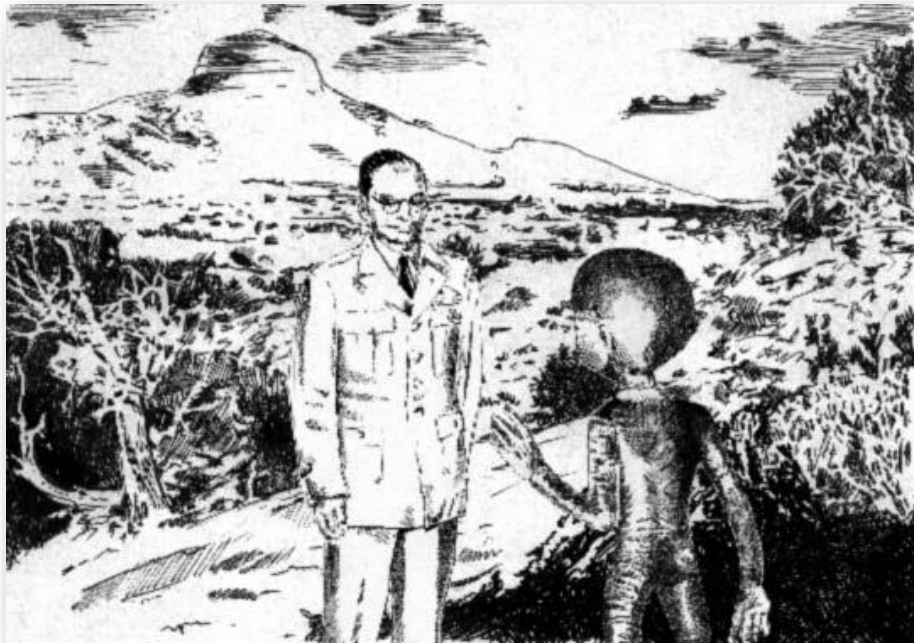

he was stationed at the White Sands Missile Range in New Mexico.

Corso was flying back from Red Canyon to White Sands and he saw on the radar something doing 3500 miles an hour. They followed it until they thought it hit the ground. So, the next day, as he was flying back home, he saw a shining object on the ground. He didn't want the pilot to know what it was so he told him to turn around and "Bring me back up".

And then he got in the staff car and found the thing. Alone, by himself, with his gun strapped on his side. He first sees the craft stuck into the side of a hill -- just as the Roswell one's are pictured.

He spotted the occupant of the UFO, but it was injured. He knew that because it was fading in and then fading out, he said, and then it would fade in. Well, he figured that he was hallucinating because it was so hot in the desert. So, he took a piece of tumbleweed threw it under it. He figured that when it would fade back in, it would crush it, and then when it would fade back out he would see it would crush. Well, that is exactly what happened.

Then he went up and touched the thing. He said it was cold. Then he turned and looked into the cave that was beside it, and inside encountered another creature. Being afraid, he came out, got back in his staff car. The creature asked him if he wanted to come aboard. He said no.

He soon realized that the craft wasn't damaged as bad as he thought it had. It had been there overnight and the ET had repaired it.

And when the craft took off, it folded within itself. It -- whomp -- and then went through a doughnut, and was gone.

He later told Dr. Oberth, one of the German scientists who worked with Von Braun, the rocket scientist, and Dr. Oberth said: "You're a magnificent person if they chose to reveal themselves to you!" He was very impressed. Then he said, "We also have had such things happen in Germany before the war." And he also said that they had far more than what the public knows about, too.

By the way, at a press conference in 1954, Dr. Herman Oberth, the German scientist credited as the father of modern rocket technology, startled many by affirming that UFOs were directed by intelligent beings of a very high order, most likely from another solar system, perhaps even another galaxy. He asserted that the spacecraft were propelled by

“distorting the gravitational field and converting the gravity into useable energy.” At an interview, some years later, he stated: “We alone cannot take the credit for our record advancement in certain scientific fields, we have been helped, helped by the people of other worlds!”

NOW WE HAVE A SECOND INTERPRETATION OF THE SAME INCIDENT:

It has been confirmed that Corso was a Battalion Commander from October 1957 to September 1958 and was at various Army Nike missile battery installations. During this time, White Sands was the largest military base in the United States and the nerve center of the Southwestern defense system.

Col. Phil Corso during a two-week period in Italy when he had gone there to attend a UFO convention, revealed in an interview to an alien encounter occurring one hot day in late summer of 1957, while he was inspecting the radar station connected to the White Sands range launching ramps. Corso was informed that an unknown blip had appeared on the radar screen. The unit followed the radar object's track until it suddenly vanished from the screen. The reason for the disappearance from the screen could be either a crash impact or a crash landing. That's exactly what Corso thought occurred and he quickly figured out the coordinates of the possible incident location in the high New Mexico desert.

In some of his writings, Corso mentions the event several times at random, giving the impression that the episode had a fundamental importance in his life.

Red Canyon is part of White Sands, and south of Los Alamos. The crash was only a few miles from his command post. He was the Senior Commander and made all military decisions. Red Canyon was in the desert 140 miles from Ft. Bliss and 100 miles from Roswell.

Having calculated the trajectory and the point of impact, Corso flew over the area in a small military plane with a young lieutenant pilot. When they

reached the site, they saw “a shiny saucer shaped object on the ground,” that Corso interpreted as a missile booster.

Two days later, Corso decided to go back to the same site, this time driving alone in his jeep.

The encounter happened in a cave in an abandoned gold mine out in the desert, only a few miles from the range area. Corso perceived a strange presence at the bottom of the cave. There was a humanoid figure that appeared transparent in the dark.

He said an alien Grey type being came out and talked to him telepathically.

When it approached Corso, he drew his gun and asked, “Friend or foe?” The being responded “neither.” Corso put his gun away. He asked the being what they intended for humanity. The being told Col. Corso that they would take us to a new world, if we could handle it.

Now whether he was talking about a new world of things on Earth, or to a completely new world somewhere else is unclear. It is a kind of ambiguous statement. The main motive of the alien at that time was to leave the area. If the alien promised something fantastic for humanity, that would give Col. Corso a reason to let it go, since it seemed to offer a benevolent reward for humanity. Talk is cheap.

Col. Corso said the being was about 4 feet tall. It wore a one-piece uniform and a silver headband on its head. The headband had what looked like a ruby in front. The aliens use those headbands to control their craft by thought as covered later in this book. It was also wearing a glove that appeared to be used to attach electrically to controls inside the ship.

The being asked Col. Corso to radio back to his base to ask them to shut off the radar, so their craft could lift off. Radar interferes with their avionics and sensitive headband and ability control their ship.

Corso felt his mind was connected to that being's mind. The core of the telepathic connection was reached when the being asked him, “Will you

give me 10 minutes, radar free, after green time?" (Green time is a military term for a launch time window.)

Being commanding officer of the radar station, Corso was in power to ask his men to block the radar/missile system and to allow the takeoff of the alien's flying object that landed in the desert. Corso communicated back to the EBE: "Ten minutes could be an eternity, what do you offer?" The being replied, "A new world if you can take it."

Without hesitation, Corso left the cave, walked to the jeep and called range headquarters by radio, asking them to make sure that after the "green time" procedure the radars were put on hold for 10 minutes. The radar unit promptly executed the order. The radars must have cleared the way for the UFO to take off, because when Corso arrived at the range, Captain Williams reported that their D-battery locked on for a minute on an object 50 miles out, traveling 3000 mph.

Now, if a UFO was plotted by the White Sands radars, the matter had to be classified top secret and it had to be handled accordingly. Corso had the highest security clearance and he decided to inspect the incident unaccompanied. His taking the responsibility to act alone corresponded with the security procedure under the circumstances.

In the absence of any confirmation by other witnesses, anyone can object and reject Corso's account. However, if what Corso is claiming is truthful, at that time flying saucers were not invulnerable at all—at least at close range—once detected by radar, they could malfunction and they could crash. (Similar to what was claimed to have brought down the craft of the Roswell incident.)

NOTE: An alien spacecraft can be disabled by directed radar beams. Col. Corso tells of a UFO that was brought down by a military radar station that locked on to the UFO and increased the strength of the radar signal, causing the UFO to lose control and crash.

NOW BACK TO THE RECOVERED ROSWELL CRAFT CORSO WAS BACK-ENGINEERING ARTIFACTS FROM:

According to Corso, they determined that the craft was a biological spaceship, functioning in conjunction with a crew of EBEs (Extraterrestrial Biological Entities). They were biological robots created through advanced genetic engineering, clones designed to withstand the extreme conditions of space travel. These EBEs were able to pilot their starship through a particular neural interface, whereby they could connect with the craft, becoming an almost integrated part of it.

CORSO OBSERVED ALIEN BODY:

Corso claimed under oath: "On or about July 6, 1947, while stationed at Fort Riley, Kansas, I personally observed a four-foot non-human creature with bizarre-looking four-fingered hands, thin legs and feet, and an oversized incandescent light bulb-shaped head. The eye sockets were oversized and almond shaped and pointed down to its tiny nose. The creature's skull was overgrown to the point where all its facial features were arranged frontally, occupying only a small circle on the lower part of the head.

There were no eyebrows or any indications of facial hair. The creature had only a tiny flat slit for a mouth and it was completely closed, resembling more of a crease or indentation between the nose and the bottom of the chinless skull than a fully functioning orifice.

In 1961, I came into possession of what I refer to as the 'Roswell File' This file contained field reports, medical autopsy reports and technological debris from the crash of an extraterrestrial vehicle in Roswell, New Mexico in 1947.

I have personally read the medical autopsy reports which refer to the autopsy of the previously described creature that I saw in 1947 at Fort Riley, Kansas.

The autopsy reports indicated the autopsy was performed at Walter Reed Hospital. The autopsy report referred to the creature as an extraterrestrial biological entity."

(NOTE: the Roswell aliens were stored at Fort Riley for a brief period in 1947 on the way to Wright-Patterson field in Dayton, Ohio. Although the Roswell alien bodies were being shipped immersed in some type of preservative fluid, after leaving Ft. Riley, they started to deteriorate at a rapid rate while being transported to Walter Reed Army Hospital for autopsy. Ft. Riley is also the home of the Army's military intelligence school. Remember hearing about the 1918 Flu epidemic that wiped-out millions of people? It started at Ft. Riley, Kansas Army Base! Any connection to biological experimentation or even aliens being there back in those days? Is there any chance that an alien fifth column has been based there for a long time?)

WHAT DO ALIENS EAT? US?

Gee, I hope not! Just recently I saw a chart listing the creatures that killed the most humans and at the top of the list was other humans, Number two on the list was mosquitos and at the bottom of the list was probably something like hedgehogs. I didn't see aliens on the list. Oh, yeah, people in the media claim that aliens don't exist. Just wait till they are attacked by a reptoid holding a knife and fork!



This subject was touched on by Corso. "The aliens can eat humans." It was the consensus of opinion in the military that the Grey aliens used human organs as a food source that was prepared and then absorbed through their skin like a plant through its roots.

This is covered in more detail in our "Secrets of the Dulce Base" Book:

<http://www.blue-planet-project.com/secrets-of-dulce-base.html>

The aliens have raised and harvested humans for food for a very long time, with major harvests being done periodically for the race of aliens that bioengineered the Greys.

Col. Corso hinted at evidence that humans are converted into some type of prepackaged food product like MREs. That should now stand for "Meals Ready for Extraterrestrials."

The Greys were genetically bioengineered by another alien race specifically for the job they are doing. They are clones bred to be worker Drones, with no sex organs or internal digestive system. They're the "hired hands," working the "farm" for the actual users of the MREs. (My guess is the Reptoids are their masters because they have been seen occasionally on the abduction saucers with the Greys, operating in a supervisory capacity.)

Col. Corso goes into great detail about how the US Army developed our MREs, and really emphasized that this type of packaged food can be stored indefinitely without refrigeration, and then eaten without the need for cooking. In our manufacture of MREs we irradiate the food after packaging and it kills all bacteria. His message wasn't lost on me that humans are just as easily processed and packaged by the aliens, to be eaten during space trips without the need for refrigeration or cooking.

This may be why kitchen facilities are not observed on alien spacecraft by abductees. Col. Corso kept hinting that the MRE preparation process was another technology we picked up from the aliens.

One of the alien facilities on the Moon may be an MRE processing plant. Did we copy their method of irradiating food for the purpose of preservation? We sure copied other alien technology and materials.

Col. Corso stated in no uncertain terms that the Greys still have an operational base on the Moon, and that NASA will not send our astronauts back there because their lives would be jeopardized. That UFOs menaced Apollo astronauts on the lunar surface. Since NASA is a civilian organization, they had no way to protect the astronauts, and so canceled the last two Apollo missions. The hardware was ready to go, but NASA shut it down claiming a "lack of public interest."

CORSO DESCRIBES THE ALIENS:

There is a lot of new information written by Col. Corso about the aliens and their spacecraft that crashed at Roswell. Autopsy reports on the aliens revealed they had a circulatory system that carried a thin milky white blood. It performed the functions of a lymphatic and circulatory system.

They had no obvious digestive, waste disposal or reproductive systems. They were bred only to work, like worker ants or Drone bees. Since they couldn't reproduce themselves, what was the purpose of their hybrid-breeding program?

Was it used to replace Greys killed by accident, old age, or craft shot down by Earth air forces? There is even a chance that it is a renegade breeding program run by the Greys to reproduce themselves so as to perpetuate their species. By creating copies of themselves (but with reproductive organs) they'd live on, in spite of the wishes of their Reptoid masters. It's a possibility.

RECENTLY REVEALED ADDITIONAL INFO ON BACK-ENGINEERED ALIEN TECHNOLOGY:

As mentioned earlier, High-tech items found aboard the Roswell craft led to the development of the transistor, microchip integrated circuits, Kevlar, the electronics that send light signals through fiber-optic lines, (more recent notes explained that not only did the tubes light-up when held in his hand, but that the light in each tube was a different color) and night vision equipment. A surgical laser was also found on the craft. The Army also developed laser and particle beam weapons systems as the craft mounted both types.

Col. Corso mentioned one piece of advanced equipment that he couldn't turn over to American industry to develop as if it were their own. He had no way to explain to a manufacturer where the technology came from because it was so advanced...

The item was a headband that had thought pickup coils in it that allowed the Greys to control their spacecraft by thought. Now they have figured it out.

The US Air Force is now using a thought control system. They now say it is based on EEG (electroencephalograph) technology. An engineer who worked for an EEG manufacturing company for many years claims that EEG machines could not be used this way. So, it must be something far more advanced than what they claim it is.

It is being developed at Armstrong Laboratory. It is an in-house Air Force research lab located at Wright-Patterson Air Force Base, home of the Air Force Foreign Technology Division.

A team of scientists at Wright-Patterson AFB are trying to harness brain power as a means of controlling aircraft systems. Experiments began at Armstrong Laboratory's alternative control technology laboratory to unleash the energy of brain waves, patterns of cerebral electricity. While in the beginning they used the technology to command a flight simulator

to roll left or right, our latest fighter jets use this technology to permit pilots to manage the deluge of data they're bombarded with in the cockpit.

In the seat, pilots must contend with a jumble of monitors, dials, knobs, buttons and switches. By installing better human-machine interfaces into the cockpit, they seek to relieve the work load from overtaxed aviators, increasing efficiency and boosting flying performance. But most importantly, rapid response by directly connecting the brain to the controls can make a difference in whether or not the mission succeeds.

CORSO CLAIMS THAT WE WERE NEVER ABLE TO FIGURE OUT SOME ALIEN TECHNOLOGY:

Amazingly, some devices from the downed alien spacecraft are still not fully understood to this day.

1. These include a high-energy microwave amplifier that has the secondary effect of decomposing solid objects into their molecular components.
2. A form of circuitry that runs on other than electrical power, using particles thought to have very short half-lives in the natural universe ("muons").
3. A huge induction generator-like coil system some 50 feet in diameter which appears to implement part of some aspect of the vehicle's ability to perform unique flying characteristics and aerobatics, some think it might be a "gravity nullifying" device.

ALIENS ON THE MOON:

Col. Corso reported that Neil Armstrong had seen an alien base on the Moon during the Apollo 11 fly over and landing. On subsequent Apollo missions, UFOs buzzed the lunar modules as soon as they left Earth orbit on the way to the Moon.

TIGHT SECURITY ON ALIEN INFO:

Col. Corso also stated that one of the reasons the military kept such tight control over UFO information was that the Russian KGB had infiltrated the CIA. If the UFO information had been released to the CIA, it would have gone straight to the Russians.

This need for secrecy got in the way many times when the Army needed money from Congress. They had to pretend the "Star Wars" weapons systems were needed to counter the Soviet missile threat, when they were really needed for defense against the aliens

People at NASA, President Carter, and Neil Armstrong all knew about this defense system but were still frightened of what the aliens were going to do. It seems we are still not out of danger, especially with military intelligence still keeping pressure on everyone not to talk!

WAS CORSO AN ABDUCTEE?:

Shortly before his death, Col. Corso told his son that he had been abducted himself right off his front porch from his house in Pennsylvania when he was a boy of six. He said he remembered everything that happened to him during the abduction and he said the alien he talked to in the desert seemed to know everything about him.

This is especially interesting in light of the fact that Corso eventually wound up in charge of the US Army Foreign Technology Division and was responsible for back-engineering all of the high-tech pieces that were recovered from the craft that crashed in Roswell.

Could it be that the alien went back in time to when Corso was six and implanted him as a means of damage control to keep a lid on the information of the crashes, contact, etc., until the Greys could get the problem handled when the Reptoids returned in force?

WHY DID CORSO TALK?

Corso said that all of the generals that knew the truth about Roswell pledged to each other that the last man left alive would reveal the truth to the public.

Col. Corso was the last one left alive and his book revealed the truth. Whether this pledge to talk later was made due to their pledge of secrecy to the military, or from mind control by the aliens or our own military using mind control on them will never be known. Alien mind control through an implant could explain why Col. Corso was Drawn to the spot where the alien craft was hovering. He also happened to be of enough rank that he could radio back and order that the base radar be shut down so the craft could leave, and the aliens obviously were aware of it.

COL. CORSO MADE THE FOLLOWING TWO INTERESTING STATEMENTS:

Maybe he knew that our military had cracked a captured saucer's computer and found the complete plans the aliens had for correcting the "trouble" they were having with us, or they may have found routine harvest scheduling information, and the next harvest was due to begin after April 2003.

And maybe he thought that our military must be ready to stop a big "human cattle roundup."

Anyway, here are Col. Corso's statements:

"And we forced the extraterrestrials to change their strategies for this planet is a story that's never been told. But as spectacular and fantastic as it may sound, the story behind the limited deployment of the SDI is the story of how humanity won its first victory against a more powerful and technologically superior enemy who discovered, to whatever version of shock it experiences, that there was real trouble down on its farm."

“Whatever we were fighting over became minimally important in the face of a threat from creatures who were so superior to us in technology that we were their farm animals to be harvested as they pleased.”



Based on the fact that our distant early warning satellites in the asteroid belt are looking for incoming “mother ships” specifically, I believe that our military plan of battle is to make it “unsafe” for them to come in for food replenishment. I personally don’t think it is a good idea to destroy lightly armed mother ships carrying many thousands of migrating Reptoids as that would make the Reptoid military come looking to settle the score.

And they would be pissed. Capturing them

would be a much better military tactic, if it becomes necessary. I believe the Reptoids value the lives of their own kind very highly. But to capture Reptoid craft and then negotiate a settlement from a position of strength requires, well, you guessed it, strength. We don’t have that strength yet. We need to get there fast. George Washington said, “To be prepared for war is the most effectual means of preventing war.”

It still holds true today. If we are not ready to defend ourselves, we have one option: surrender, and let the other side do whatever they have in mind. Besides, it is not usually a good idea to try to start into a business or trading relationship by us blowing up and killing our prospective customers. So, we will have to negotiate from a position of strength, so they will listen.

We should know by now that the Reptoids are not our friends or space brothers. They have been here in the past and only wanted high human body counts from human sacrifices, war, and plagues. They had the power through electronic mass mind control capabilities to stop any wars, sacrifices; and the know-how to cure epidemics. The Greys have cured abductees of major diseases including AIDS. Yet they will let epidemics wipe out millions of people when they need bodies because it was harvest time.

There were always massive saucer flaps seen and recorded during and after those high fatality events, and the aliens did NOTHING to stop the carnage. In fact, the aliens have openly helped to create carnage, such as the "flying shield" incident when a saucer used an energy weapon to blast open the walls around the city of Tyre, so that the army of Alexander-The-Great could rush in and slay all of the inhabitants of the city.

Dr. Michael Wolf

American scientist Dr. Michael Wolf claimed he was a member of the satellite government for over 25 years. He attained a very high 'Above Top Secret' clearance level and worked primarily on joint ET/human scientific projects.

He died on September 18th, 2000 from cancer after a long period of ill-health. During his final years, he spent time talking to various journalists about the UFO and ET cover up. His bosses at the National Security Council (NSC) gave him permission to 'generate a controlled leakage of secret information'.

As Dr. Wolf commented:

"I look forward to the day when the secrecy surrounding extraterrestrial contact ends so that our race can move forward to the next phase of its history - now cosmic in scale."

As is standard practice, these superiors have erased almost all his records such as the universities he attended; degrees gained; and his involvement with the CIA, NSA and NSC.

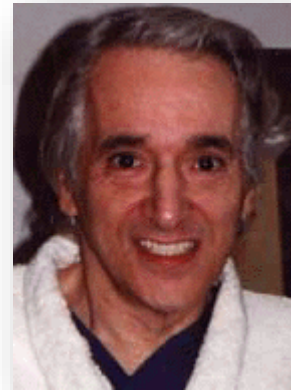

Such measures are common for people working in unacknowledged 'special access programs' as their bosses must maintain plausible deniability in case a sensitive unauthorized disclosure occurs.

Dr. Wolf said he worked in laboratories at Area 51, S4, Wright-Patterson Airforce base (Foreign Technology Division), Indian Springs and Dulce. Where for five years, "I met with extraterrestrial beings every day in my work and shared living quarters with them."

He served as a scientific consultant for the American President and NSC on ET related matters.

He was a member of MJ-12 special studies group and appointed head of its leading agency - the Alphacom Team - which specializes in gathering information on the different ET races. Dr. Wolf said he had an MD in neurology; a Ph.Ds. in theoretical physics; a BS in biogenetics; a JD in international law; and a D.Sc. in computer sciences.

The UFO community was first alerted to Dr. Wolf by the publication of his highly original and unique book 'Catchers of Heaven' in July 1996. A book primarily about his experiences while working for the satellite government. Since then prominent researchers like James Courant, Michael Hesemann, Dr. Steven Greer, Art Bell and Bruce Burgess have been knocking on his door.

It took '15 years of persuasion' before his bosses finally allowed him to publish. But their conditions stated that this book must be fictionalized and to have three different denials at the beginning concerning its authenticity. They also reviewed 'Catchers of Heaven' before publication.

He commented, "I would like on my gravestone the words, 'He died of red tape'."

While some of Dr. Wolf's claims may sound pure science fiction, if genuine, then he is probably the highest-ranking member of the satellite government to come forward so far - offering us an extraordinary insight - a tantalizing glimpse - into the UFO cover up and ET reality.

[DR. MICHAEL WOLF CLAIMED THAT:](#)

The first US crash/retrieval of an ET craft occurred during 1941 in the ocean west of San Diego. Retrieved by the navy, dead Zeta Reticulans, alias the 'Greys', were found inside. Craft and bodies were taken to the Foreign Technology Section at Wright-Patterson Airforce base in Dayton, Ohio, and studied by the Retfours Special Studies Group. After dismantling the

craft parts were sent to S4 and Indian Springs in Nevada. This craft crashed due to the recently invented pulse radar being tested on the nearby Tinian island, located three miles south/south west of Saipan. The US navy has held a leadership position in UFO matters since.

The Roswell Crash during July 1947 did happen and that the account in Colonel Corso's book 'The Day after Roswell' is accurate. Dr. Wolf had, in his possession, the official satellite government ET crash/retrieval list and while others occurred between 1941 and '47 he was not willing to offer examples.

Two craft crashed at Roswell after colliding with each other during an electrical storm. One contained 'Greys' the other 'Orange' ETs - both named due to the color of their skin. The 'Orange' types come from the Andromeda star system. The Santilli autopsy film is genuine – Dr. Wolf had seen other similar footage – and it is an autopsy of an 'Orange' ET. There were two different autopsies being carried out on two different ET beings during the same period - hence the confusion.

The autopsy on the 'Orange' ET revealed that it had a very large head; big dark eyes with no irises or whites; six digits on hands and feet; the brain has four lobes; is more developed and connected with no corpus callosum; different optic orbs and nerves; and a sponge like digestive system. Dr. Wolf said he'd met one alive.

There are different types of 'Greys'. He worked alongside highly evolved ones which had, contrary to present opinion, personalities and even a sense of humor. Dr. Wolf never met a 'Grey' whom he disliked. To him they were family. (A conclusion much different from almost everyone else's.

Their smooth and soft bodies feel like dolphin skin to touch. He communicated with these ETs through telepathy. Dr. Wolf became especially friendly with one called Kolta. A picture of this 'Grey' is on the front cover of his book - an actual photograph taken by an admiral friend.

There is active trading between the 'Greys' and 'Oranges'. Dr. Wolf said, "Trading has a different meaning for ETs. They share knowledge like technology and philosophy and send their people to each other's planet to learn the culture."

He had conversed with human looking ETs from the Pleiades and Altair star systems - nicknamed the Nordics and Semitics. Dr. Wolf explained they are very spiritual people and act more as galactic counselors. A photograph of a Pleiadean friend called Sa Ra adorns the back cover of his book.

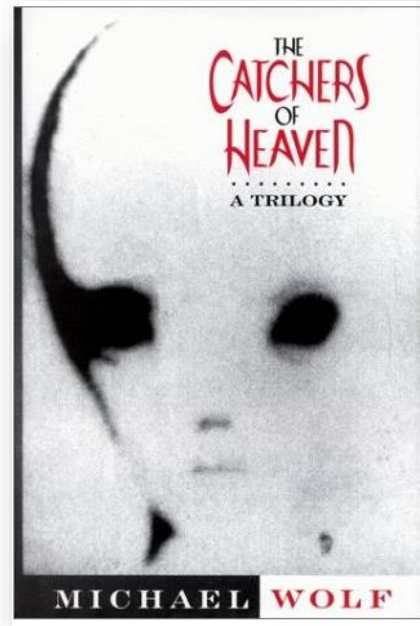

Photo of the Grey named Kolta on his book

On May 1st, 1975, a 'little misunderstanding' occurred between the 'Greys' and humans at S4. During a demonstration of a small anti-matter reactor the head ET asked the guards, Blue Beret soldiers, to remove their rifles and bullets from the room. A safety precaution so these weapons wouldn't accidentally discharge during the energy emissions. The guards refused and in the ensuing commotion a Blue Beret opened fire and killed a 'Grey'. Two scientists and 41 military personnel were then terminated. One guard was allowed to live - testifying that the 'Greys' used a form of directed mental energy at them in self-defense.

A number of the scientists presently working for the satellite government were abducted when they were children by the 'Greys' so their intelligence and general brain capacity could be increased in preparation for the work ahead. They are hybrids.

His first major assignment was working alongside Carl Sagan and other top scientists - their job was to understand the intricacies of a huge ET beacon dubbed The Monolith - first discovered floating out in space by Russian

cosmonaut Yuri Gagarin and American Alan Shephard during 1961. It was eventually brought back for investigation in 1972. Dr. Wolf described it as 'postcards from the rim'. The Monolith emits both light and tone signals along with a mathematical language.

On closing your eyes, while tuned into these signals:

"You see in your mind's eye a 3D film of the Galaxy. But you are actually there as if part of this film. The images being seen today by the Hubble telescope are the same ones I saw 25 years ago."

Dr. Wolf said there are many Monoliths out in space and were devised by a group of ET races.

Carl Sagan consistently denied the ET reality because his superiors, "Threatened to cut off the funding to his department at Cornell University if he said otherwise."

He was involved in various genetic experiments - one being the Sentinel Project. After perfecting cloning techniques on animals Dr. Wolf and his associates successfully created an artificially-intelligent human named 'J-Type Omega' - their superiors wanted a super-bright, super-powerful soldier who would follow orders without fear or question. But Dr. Wolf surreptitiously programmed ethics into its intelligence after realizing that 'J Type' had a soul. When the being refused to kill a harmless dog his superiors ordered its termination. Instead, Dr. Wolf set 'J Type Omega' free. This 'intelligence' is presently living somewhere in America.

MJ-12 does exist and now has 36 members. He was reluctant to divulge names although confirmed that former American Secretary of State, Henry Kissinger and father of the hydrogen bomb, Edward Teller, were present members. MJ12 regularly meet at various secret locations including the Batelle Memorial Institute at Columbus, Ohio.

The Sentinel Project involved a close association with the 'Greys'. The ETs vast knowledge on genetics being essential for its success. 'J Omega' was

grown in a water tank from an embryo. Part of the DNA used came from Dr. Wolf. It took exactly one year before he was ready to be 'awoken'.

Dr. Wolf said, "When taken from the tank he looked around 20 years old."

When 'J' awoke, "He was like a puppy dog - his mind a vacuum. He asked question after question. He wanted to know everything."

Dr. Wolf showed him film reels about Earth's past wars and conflicts.

"He cried when he saw these horrific images. In hindsight, I showed him too much."

He learnt several different languages and could use 50% of his brain - unlike the mere 10% harnessed by humans. "When his mental abilities were tested his IQ shot off the map." Their relationship was like father and son.

Harvesting of animal tissue, through the so-called 'Cattle Mutilations', is to produce organelles - specialized parts of a cell that resemble and function like an organ - which can be placed into humans for filtering out pollutants from the air, water, food etc... Present experimentation is being carried out on the hybrids - part Zeta/part human - or 'In-Betweens' as Dr. Wolf called them.

These organelles can also be used to alter the body's hormones and for changing precursors in the brain from being toxic to non-toxic. "These cells are minute and involves a non-invasive procedure." Cattle genetics are very similar to humans.

When Dr. Wolf's superiors ordered 'J Omega's' termination, with the help of a general friend, he smuggled him out of Area 51. "To me it felt like a sin to create a being with emotions and a soul and then send him into battle."

'J' is now safe and well. Several organelles were placed in his body to keep him disease free. "He knows who he is and how he was created. 'J' is almost identical to a human and would easily pass a medical examination."

The Zetas were pleased with the result. " 'J' told me he wished to become a teacher." Dr. Wolf believed this was a one-off project. "I told him never to contact me. It's too dangerous."

He briefed four different American presidents on the ET reality. Jimmy Carter was keen to end the UFO cover up but when told of the religious implications he backed down.

"I attended this meeting. Carter had strong Christian beliefs. When told that religion is man-made and probably unique to this planet he broke down in tears."

Both Ronald Reagan and George Bush are very knowledgeable on the ET reality - especially Bush, being former head of the CIA. Bill Clinton was the least aware. He knows of Area 51 but not S4.

"Clinton had 'Above Top Secret' and 'Need to Know' clearances but did not have the 'Umbra Ultra Top Secret Clearance' which gives access to upper level MJ12 secrets and 'Keystone Clearance' for information on ET research."

Many people in MI5, MI6 and the SAS are aware of the ET reality. While reluctant to give names of those he briefed at Downing Street, when staying in London he became good friends with former Conservative cabinet and defense minister Sir Malcom Rifkind.

"Rifkind is very knowledgeable on the UFO subject - especially the flying triangular craft. He believes the cover up is correct. That people are not ready to be told yet."

We unofficially landed on the moon before 1969 although he wouldn't give a date.

"Our astronauts were observed then communicated with by ETs while on the Moon. We were warned off the planet. That's why the last Apollo mission was cancelled at the last second. The astronauts are dying to tell the truth but know it could be interpreted as treason."

NASA has played an integral role in the UFO cover up. They have been designated as one of the primary organizations to eventually tell the world about the ET reality.

Richard Hoagland is primarily correct concerning structures on Mars and confirms that we have bases on both this planet and the Moon. The Face on Mars photograph, which shows a very different image from the previous one, has been doctored by NASA. "They believe humanity is not ready for this knowledge."

In a chamber at Giza and another located between the paws of the Sphinx skeletons of 7 ft. tall beings with large eyes have been discovered - their hands and legs chained together with silver.

"For some reason, early ET visitors could not break through silver."

A Stargate has been discovered in a Giza pyramid. Investigating scientists believe it to be a lens which creates wormholes to any part of the universe. It hasn't been activated yet.

"We need to know a lot more about this Galaxy and others before using it - where you want to go and how to prepare yourself. It's about what you dial in. Co-ordinates have to be established. The problem is there are no traffic signs out in space."

Dr. Wolf felt this will be one of the last projects we'll learn about through our association with the ETs. He personally pioneered a mental expansion process called The Gateway treatment. An experiment to:

"Open the brain up - a way to stimulate the neurons allowing billions of synapses to form and therefore use of a vast increased mind."

One off-shoot is an ability to telepathically communicate with the ETs.

This mental expansion developed into a series of mind control experiments under the name MK ULTRA. Dr. Wolf and colleagues learnt how to extract as well as repress human memories. The latter is called Mind Capping.

"These techniques are not as effective as the ET methods."

This also lead to research on remote viewing and other psychic phenomena. "The end result of all these experiments may be an attempt by some at world mind control - a chilling thought."

There is a group of impotent, xenophobic and paranoid generals, charged with the protection of American skies, who fear and hate the ETs and are waging war against them.

Called the Cabal, they use Star Wars weaponry including a neutral particle beam to shoot down ET craft and imprison survivors while attempting to extract information by force.

"The very technology the ETs gave us is now being used against them."

Despised by many within the satellite government this Cabal also use aggressive methods against those who try to end the UFO cover up. A concern being that this aggression will intensify as the big announcement Draws ever closer.

Leading UFO researchers and members of the satellite government who are presently helping to end the cover up may have been zapped by psychotronic directed energy devices owned by the Cabal.

People like:

Dr. Steven Greer and assistant Shari Adamiak (CSETI), Congressman Steve Schiff, USAF Col. Steven Wilson (former head of crash/retrieval unit Project Pounce), Dr. Michael Wolf himself and his primary unnamed CIA superior, ...plus others have either recently died or are suffering from cancer related illness. Coincidence?

Through his genetic experiments, he found that some humans, including himself, have ET gene markers. "Many people who are actively involved in the UFO field will probably have these genes."

Several different confederations of ETs are visiting us. They include:

The Alliance consisting of human looking beings from the Altair Aquila and Pleiades star systems, The Corporate made up of various 'Grey' races

from the Zeta Reticuli system, The Federation of Worlds which include an unspecified number of different ET groups from the universe, The United Races of Orion which consist of various beings from that star system. These confederations are also inter-linked with each other.

The Vatican is especially worried over these forthcoming disclosure announcements. They have asked the American government to hold back, especially on the religious question, so there is more time for them to prepare.

Dr. Wolf said the Pope has changed the Roman Catholic view on God.

"Their future line will be 'we are not in the image of God but our souls are'."

He had spoken at length to the ETs about God and death.

"Our bodies are merely containers for the soul. When people die their consciousness simply moves into another dimension."

On God, Dr. Wolf said, "Some ETs call God The Forever - the creator behind everything in the universe."

On Jesus Christ, "He was of joint ET/human heritage - sent to Earth as an attempt to end human violence."

Whether a Zeta, Pleiadian, Altaran, Human etc., we share the same God - we are all family.

Dr. Strecker's published research report, identifying HIV/AIDS as caused by a man-made virus, is correct. The satellite government has discovered that viruses are crystalline in structure and using the correct frequency can destroy them.

The US had in their possession a 'Grey', dubbed EBE (Extraterrestrial Biological Entity), as a prisoner/guest from 1948 until its death in 1953. Scientists initially used pictographs as a form of communication.

Albert Einstein had met and worked alongside the 'Greys'.

Some ETs occasionally eat vegetation, fruits or vegetables. Their digestive systems are far more efficient than ours absorbing and processing

thoroughly. They mainly absorb energy from the air. Visits to the toilet are not required!

Earth is one of the few planets which doesn't control its weather. That's one reason why ET ships crash during extremes of climate - especially those ships using gravity propulsion.

Dr. Wolf says, "Their craft are no different from boats in a violent storm - bobbing up and down on large rolling gravity waves. To counteract these difficulties, some ETs surround their ships with plasma energy or fly inter-dimensionally through a storm."

A planet is a living entity with its own consciousness. ETs commune with their planet to create a harmonious relationship.

Dr. Wolf says, "Some planets grow buildings of pure silicon for the inhabitants out of unconditional love. I have seen and held this silicon. I have also witnessed Zetas communicate with Earth."

ETs are astounded by how badly we treat Earth. They can't understand why we wish to destroy it. How multi-nationals can continually rape this planet through their greed and avarice. One of the Alphacom Team missions is to determine whether, "We can use the ETs technology to restore Earth to its former pristine state of natural balance."

Technology gained from the ETs include:

- LEDs
- superconductivity
- computer chips
- fiber optics
- lasers
- gene-splicing therapy
- cloning
- night-vision equipment

- Stealth technology
- particle beam devices
- aerospace ceramics
- gravity control flight

ETs like many things about humans. Dr. Wolf explained, "They especially love our great imagination and creativity along with the ability to have profound Dreams. But they would like to speed up our spiritual evolution."

Many ETs who visit Earth are actual tourists. While we take holidays in other countries more advanced beings visit other worlds.

"Compared to most planets, Earth is almost unique with its vast diversity of nature, culture and inhabitants. As primitive planets go we are a popular attraction."

Some ETs prefer living underground as they can control the environment to suit their needs. They also use electro-magnetic shielding where the molecules are so dense that nothing can get through.

Dr. Wolf hinted, "We still haven't explored the deep oceans or the inner crusts of Earth."

Alphacom Team discovered that many human looking ETs are presently amongst us. He said, "They can breathe our air and on the street, would look exactly like us."

Around 1,000 Nordic types are living in Spain alone.

A Nordic has a perfect and very sensitive looking face with few lines; blue eyes; usually blond hair; around 6 ft. tall; very clean; no body odor; and mainly communicates telepathically. But while on Earth uses a small implanted voice-box to converse with humans.

Their internal organs are fairly similar to ours although the digestive system is different. They don't need to eat every day. Their cells don't die because

the genetics are dissimilar. They have a base on a French Polynesian island and walk freely amongst the inhabitants.

Nordics have powerful minds. Dr. Wolf said, "They can open a dimensional portal just through a single thought and physically disappear. I have seen this done. They live on a much higher plane than us. Thoughts are an energy and Nordics use a device, either worn or placed in a pocket, that amplifies this energy. They also harness crystals for the same purpose."

During one afternoon in 1990 an ET craft, escorted by F-16 fighters, landed on Puerto Rico, in a busy tourist area. The ETs stepped out and walked amongst the populace. Dr. Wolf said, "It was an exercise to test the public reaction."

The Mayor of this island wrote a letter to Bush stating, 'At first we were amused by all of the sightings but then people became distressed. What do I tell them?' The President passed this communication onto Dr. Wolf.

"It was stamped all over with the words T52-EXEMPT (E) which means this letter can never be declassified."

While studying at MIT for his PhD in physics he discovered a new theory of wave particle duality which later developed into a neutral particle beam.

Dr. Wolf commented, "I had hoped and envisioned that this technology would be used for treating cancer. Instead it was used as a weapon as part of the SDI Program (Star Wars)."

The ETs told him, "All worlds in the Galaxy are connected. One Hiroshima atomic bomb can affect every different culture."

They also explained, "Thought is energy. It can be received on other worlds. There is no galactic barrier."

Mossad, Israel's intelligence organization, "has very good relations with the ETs - especially the Semitics." There is a strong historical association with the country.

The top-secret space plane, The Aurora, runs on liquid methane and has anti-gravity on board. It carries an electromagnetic pulse weapons' system which can knock out tracking radar. This plane can also travel to the moon.

Some military pilots are experimenting with mind control to guide advanced planes.

Dr. Wolf said, "Some ET craft are living conveyances which are able to divide and reform. These craft are also responsive to thought commands."

The underground base at Area 51 is a sprawling city, the size of Rhode Island, which continues to grow and has a sister base called S4, some 12 miles away, and another named Indian Springs. It employs hundreds of civilian and military and has at least 8 different on-going black programs along with an annual \$2 billion budget.

There's intense security outside with martial law inside and is patrolled by elite guards. Some scientists live at the base for 6 months at a time. While their bedrooms are basic, the ETs live in their own magnificently designed apartments. There are also shopping malls, military style shops and leisure areas including swimming pools, gymnasiums and basketball courts. The food is excellent.

Satellite government scientists have successfully created zero-point energy and cold fusion.

"There needs to be a smooth transition into these new sciences. Otherwise the world economy could be wrecked."

As part of his work with the Government, Dr. Wolf pioneered an amazing mental technique known as THE GATEWAY TREATMENT.

This technique had two purposes: In Wolf's own words: "It opens up the brain. Gateway is a way to stimulate the neurons allowing billions of synapses to form and, therefore, allows the person that masters it to have use of a vastly increased mind." And enable one to telepathically communicate with and summon positive Alien Entities.

Nikola Tesla - Alien Communications, Star Wars Technology

In 1899, Nikola Tesla, with the aid of his financial backer, J.P. Morgan, set up at Colorado Springs an experimental laboratory containing high-voltage, radio transmission equipment. The lab had a 200-ft. tower for transmission and reception of radio waves and the best receiving equipment available at the time.

One night, when he was alone in the laboratory, Tesla observed what he cautiously referred to as electrical actions which definitely appeared to be intelligent signals. The changes were taking place periodically and with such a clear suggestion of number and order that they could not be traced to any cause then known to him.

Tesla elaborated on the subject of Talking with the Planets in Collier's Weekly (March 1901):



"As I was improving my machines for the production of intense electrical actions, I was also perfecting the means for observing feeble efforts. One of the most interesting results and also one of great practical importance, was the development of certain contrivances for indicating at a distance of many hundred miles an approaching storm, its direction, speed and distance traveled.

"It was in carrying on this work that for the first time I discovered those mysterious effects which have elicited such unusual interest. I had perfected the apparatus referred to so far that from my laboratory in the Colorado mountains I could feel the pulse of the globe, as it were, noting

every electrical change that occurred within a radius of eleven hundred miles.

"I can never forget the first sensations I experienced when it dawned upon me that I had observed something possibly of incalculable consequences to mankind. I felt as though I were present at the birth of a new knowledge or the revelation of a great truth. My first observations positively terrified me as there was present in them something mysterious, not to say supernatural, and I was alone in my laboratory at night; but at that time the idea of these disturbances being intelligently controlled signals did not yet present itself to me."

"The changes I noted were taking place periodically and with such a clear suggestion of number and order that they were not traceable to any cause known to me. I was familiar, of course, with such electrical disturbances as are produced by the sun, Aurora Borealis, and earth currents, and I was as sure as I could be of any fact that these variations were due to none of these causes."

"The nature of my experiments precluded the possibility of the changes being produced by atmospheric disturbances, as has been rashly asserted by some. It was sometime afterward when the thought flashed upon my mind that the disturbances I had observed might be due to an intelligent control.

"Although I could not at the time decipher their meaning, it was impossible for me to think of them as having been entirely accidental. The feeling is constantly growing on me that I had been the first to hear the greeting of one planet to another. A purpose was behind these electrical signals."

This incident was the first of many in which Tesla intercepted what he felt were intelligent signals from space. At the time, it was surmised by prominent scientists that Mars would be a likely haven for intelligent life in our solar system, and Tesla at first thought these signals may be originating from the red planet. He would later change this viewpoint as he became

more adept at translating the mysterious signals. Near the end of his life, Tesla had developed several inventions that allegedly could send powerful amounts of energy to other planets.

In 1937, during one of his birthday press conferences, Tesla announced, "I have devoted much of my time over the years to the perfecting of a new small and compact apparatus by which energy in considerable amounts can now be flashed through interstellar space to any distance without the slightest dispersion."

(New York Times--July 11, 1937.)

Tesla never publicly revealed the technical details of his improved transmitter, but in his 1937 announcement, he revealed a new formula showing that:

"The kinetic and potential energy of a body is the result of motion and determined by the product of its mass and the square of its velocity. Let the mass be reduced, the energy is reduced by the same proportion. If it be reduced to zero, the energy is likewise zero for any finite velocity."

(New York Sun--July 12, 1937, pg. 6.)

After his initial Colorado Springs experiments in 1899, Tesla started experimenting with better radio transmitters and receivers in order to repeat his reception of the anomalous signals he picked up in Colorado.

Tesla considered his methods of reception and transmission utilized not Hertzian waves, or what we now refer to as transverse electromagnetic waves (radio), but another type of signal transmission.

He described them as faster-than-light (FTL) longitudinal wave transmissions. Tesla may have been receiving on the ELF spectrum (Extremely Low Frequencies).

The ELF spectrum is below the 10 KHz. boundary of internationally regulated frequencies. It is usually considered to be the spectrum of 3 Hz. to 30 Hz.

- VLF-3 to 30 KHz.
- ULF-300 to 3000 Hz.
- ELF-3 to 300Hz.

The wavelengths in the ELF range are from 100,000 Km. to 1,000 Km. and the wavelength for the earth's 40,000 Kms. Circumference falls within that spread.

By the 1920's Tesla had grown confident that he was able to make sense of the strange radio broadcasts from space. However, soon afterwards, Tesla began to express great concerns about beings from other planets who had unsavory designs for planet Earth.

"The signals are too strong to have traveled the great distances from Mars to Earth," wrote Tesla. "So, I am forced to admit to myself that the sources must come from somewhere in nearby space or even the moon. I am certain however, that the creatures that communicate with each other every night are not from Mars, or possibly from any other planet in our solar system."

Several years after Tesla announced his reception of signals from space; Guglielmo Marconi also claimed to have heard from an alien radio transmitter. However, Marconi was just as quickly dismissed by his contemporaries who claimed that he had received interference from another radio station on Earth.

Tesla, on the other hand, had perfected his equipment to such a degree that he was soon receiving voice transmissions. These transmissions he speculated were originating from people on other worlds. Tesla gave a few public hints about these interplanetary transmissions, such as in 1937, he announced:

"I have devoted much of my time during the year past to the perfecting of a new small and compact apparatus by which energy in considerable amounts can now be flashed through interstellar space to any distance without the slightest dispersion."

(New York Times, Sunday, 11 July of 1937).

A degree of confirmation of Tesla's interplanetary communications came from Arthur Mathews who claimed that Tesla had secretly developed the "Teslascope" for the purpose of communicating with Mars. Matthews' father was a laboratory assistant to the noted physicist Lord Kelvin back in the 1890s.

Tesla once came over to England to meet Kelvin to convince him that Alternating Current was more efficient than Direct. When Matthews was 16 his father arranged for him to apprentice under Tesla. He eventually worked for him and continued this alliance until Tesla's death in 1943.

It's not generally known, but Tesla actually had two huge magnifying transmitters built in Canada, and Matthews operated one of them. People mostly know about the Colorado Springs transmitters and the unfinished one on Long Island. I saw the two Canadian transmitters. All the evidence is there.

The Teslascope is the thing Tesla invented to communicate with Beings on other planets. In principle, it takes in cosmic ray signals and eventually the signals are stepped down to audio. Speak into one end, and the signal goes out the other end as a cosmic ray emitter.

With the exception of Matthews' statements, there has been no concrete evidence that Tesla managed to communicate with extraterrestrials or whoever was transmitting to Tesla's ELF receiver. It seems that Tesla was on the receiving end only.

Nevertheless, Tesla managed to glean a substantial amount of good information from these transmissions, enough to influence his research and inventions for the remaining forty-three years of his life.

It was during this period that Tesla found himself ostracized by most of the scientific community. His efforts to interest others in such wild inventions as:

- free-energy

- beam weapons
- wireless power transmission
- antigravity devices
- anti-war shields
- resonation
- and a plethora of others

No doubt led to him being considered a crackpot. Sadly, Tesla had become the epitome of a mad scientist.

Yet, it was obvious that his letters to the government and military had aroused some interest. A young American engineer engaged in war work consulted Tesla on a ballistics engineering problem because he could not get time on an overworked computer, and Tesla's mind was known to offer the nearest thing to it.

Soon he became fascinated with Tesla's scientific papers and was allowed to take batches of them home to his hotel room where he and another American engineer pored over them each night. They were returned the next day, a procedure that continued for about two weeks prior to Tesla's death.

Tesla had received offers to work for Germany and Russia. After the inventor died, both engineers became concerned that critical scientific information had fallen into foreign hands and alerted United States security agencies and high government officials.

Just how much of Tesla's work remains hidden in the top-secret bowels of the military is unknown. It can be deduced that Tesla's theories of extraterrestrials and global warming were taken seriously by some in high-levels of authority, because it is now known that the United States government and military were the first to give credence that UFOs were spacecraft from other planets.

It is interesting to note that between 1945 and 1948 an exchange of letters and cables occurred among the Air Technical Service Command at Wright Field in Dayton, Ohio, Military Intelligence in Washington, and the Office of Alien Property. The subject? Files of the late Nikola Tesla.

On September 5, 1945, Colonel Holliday of the Equipment Laboratory, Propulsion and Accessories Subdivision, wrote to Lloyd L. Shaulis of the OAP in Washington, confirming a conversation and asking for photostatic copies of the notes and papers of the late Tesla. It was stated that the material would be used "in connection with projects for National Defense by this department."

Shaulis made the material available to Air Technical Service Command, but there is no record of how many copies were sent. Nor was the material ever returned. These were full photostatic copies, not merely the abstracts. The Navy has no record of Tesla's papers; no federal archives have records of them.

Four months after the photostats had been sent to Wright Field, Col. Ralph Doty, Chief of Military Intelligence in Washington wrote James Markham of Alien Property indicating that they had never been received:

"This office is in receipt of a communication from Headquarters, Air Technical Service Command, Wright Field, requesting that we ascertain the whereabouts of the files of the late scientist, Dr. Nikola Tesla, which may contain data of great value to the above Headquarters.

It has been indicated that your office might have these files in custody. If this is true, we would like to request your consent for a representative of the Air Technical Service Command to review them. In view of the extreme importance of these files to the above command, we would like to request that we be advised of any attempt by any other agency to obtain them.

"Because of the urgency of this matter, this communication will be delivered to you by a Liaison Officer of this office in the hope of expediting the solicited information."

The "other" agency that had the files, or should have had them, was the Air Technical Service Command itself. On October 24, 1947, David L. Bazelon, Assistant Attorney General and Director of the Office of Alien Property, wrote to the commanding officer of the Air Technical Service Command regarding the Tesla photostats. They had not been returned and the OAP wanted them back.

Obviously at least one set of Tesla's papers had reached Wright Field because on November 25, 1947, there was a response to the Office of Alien Property from Colonel Duffy, chief of the Electronic Plans Section, Electronic Subdivision, Engineering Division, Air Material Command, Wright Field.

He replied:

"These reports are now in the possession of the Electronic Subdivision and are being evaluated. This should be completed by January 1, 1948. At that time your office will be contacted with respect to final disposition of these papers."

They were never returned or even acknowledged to have ever existed at all.

In response to a Freedom of Information Act request in 1980, Wright-Patterson Air Force base stated:

"The organization (Equipment Laboratory) that performed the evaluation of Tesla's papers was deactivated several years ago. After conducting an extensive search of lists of records retired by that organization, in which we found no mention of Tesla's papers, we concluded the documents were destroyed at the time the laboratory was deactivated."

STAR WARS - SCALAR WAVES AND TESLA SHIELDS:

In recent years, the proposal of a "Star Wars" system in space has gained a great deal of momentum and controversy. This proposed system is said to be the ultimate system to insure the security of the United States--and the



world, at least by those who propose it. Those fighting against it maintain that it is not technically feasible.

Supporters in the Reagan Administration propose a system that would work like this: when Soviet ICBM missies, loaded with their nuclear payloads, are launched at the U.S., the "Star Wars" system, hovering

in space, would fire super-high powered Lasers at the missiles while they are still in the air, thereby disabling them. These super-high powered Lasers would be powered by small atomic explosions within the "Star Wars" satellites themselves.

Critics charge that Laser technology has not advanced enough to enable the United States, or any country, to pull off such a feat. Yet another alternative rarely discussed in the media is available, and it is a technology fifty years old, invented by Nikola Tesla, the electrical genius who lit the world: Scalar Waves!

Scalar Waves are a form of radio waves creating what is known as Longitudinal Wave Interference. Where two Scalar Waves meet, an energy bottle is created which disintegrates all matter within that bottle, producing what is in effect a miniature atomic explosion but without any resulting radiation.

Thomas Bearden, a retired Pentagon war games expert and active consulting engineer to the Defense Department, has written a number of papers on Scalar Wave systems and often lectures on Scalar Waves at Alternative Energy conferences. According to Bearden, the Soviets are way ahead of the U.S. in Scalar Wave technology and are already using it against the U.S.

Scalar Wave technology is apparently very real and deadly. Furthermore, it is a great deal more simple to use than Lasers, far more effective, and does not require mini-atomic explosions to power it. Is it possible that Scalar "Howitzers," as they've been called, is the real system that the Pentagon would like to put into space? What applications might such a system have?

The Pentagon has insisted so far that their proposed "Star Wars" program is entirely defensive, designed to protect the U.S. from a nuclear attack. Incredibly, Ronald Reagan even said in a press conference once that after the United States had built their "Star Wars" system, they would give it to the Russians, who would then build their own system in space, so the world would be theoretically safe from nuclear war for ever more! Reagan later said in another news conference that maybe this wasn't such a good idea after all.

When a "Stars Wars" system using Scalar Wave technology is activated, its uses are in fact more "offensive" than "defensive." Scalar Wave weapons are a weapon of such incredible power and versatility, that no one on our planet would be safe from them. Given the proper coordinates, the Scalar transmitters located on satellites in space could disintegrate any target on the planet, be it a missile, enemy base, rioting city district, farm house or persons gathering in a park. Such a "Star Wars" system would be a literal "Death Star" in space! Its uses could be population control, extermination, and military domination of an entire planet. George Lucas may be more of a prophet than he realizes.

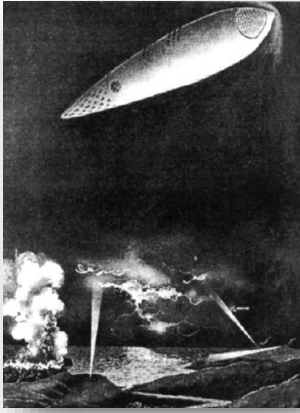

On the brighter side, Scalar Waves can be warped into a dome around objects, such as cities or houses. Such a Scalar Wave force field is generally known as a Tesla Shield, and it would be analogous to the "shields" referred to in the popular "Star Trek" series. Tesla Shields have a definite defensive application, and could not in any way be used for offensive purposes (although a platoon of soldiers charging into a Tesla Shield would be instantly disintegrated).

The only defense from a blast of a Scalar Wave Howitzer would be a Tesla Shield.

Therefore, those persons wishing to use Scalar Waves on an unsuspecting population would rather that they were unaware of this technology, and thereby unable to protect themselves by use of the same technology. Is this the reason that the Pentagon does not discuss Scalar Wave technology, but rather maintains that they are going to use impractical Laser technology instead? (Or maybe I shouldn't even be describing this.)

Scalar Wave Technology is straight out of science-fiction, yet it was invented more than fifty years ago by Nikola Tesla. Another interesting application of Scalar Wave technology is its use in "Light Sabers." If a Scalar Wave emanates from a grip-able handle and then is bent back on itself, it would become exactly like a "Light Saber" as depicted in the "Star Wars" movies featuring Jedi Knights (written and produced by George Lucas).

Are Scalar Waves a real technology? Do the Soviets have this technology? Assuredly so. The Americans do as well. The secret American base at Pine Gap in Central Australia is said to have two Scalar Wave towers in it already. Does the Pentagon really plan to put Scalar Wave Howitzers into space? If so, is it purely for defensive purposes?

TESLA SHARES SOME OF HIS INNER THOUGHTS (POWERS?):

"In my boyhood I suffered from a peculiar affliction due to the appearance of images, often accompanied by strong flashes of light, which marred the sight of real objects and interfered with my thoughts and action. They were pictures of things and scenes which I had really seen, never of those imagined.

When a word was spoken to me the image of the object it designated would present itself vividly to my vision and sometimes I was quite unable to distinguish whether what I saw was tangible or not.

This caused me great discomfort and anxiety. None of the students of psychology or physiology whom I have consulted, could ever explain satisfactorily this phenomenon.

They seem to have been unique although I was probably predisposed as I know that my brother experienced a similar trouble. The theory I have formulated is that the images were the result of a reflex action from the brain on the retina under great excitation. They certainly were not hallucinations such as are produced in diseased and anguished minds, for in other respects I was normal and composed.

To give an idea of my distress, suppose that I had witnessed a funeral or some such nerve-wracking spectacle. Then, inevitably, in the stillness of night, a vivid picture of the scene would thrust itself before my eyes and persist despite all my efforts to banish it from my innermost being.

I also began to see visions of things that bore no resemblance to reality. It was as if I was being shown ideas of some cosmic mind, waiting to make real its conceptions.

If my explanation is correct, it should be possible to project on a screen the image of any object one conceives and make it visible. Such an advance would revolutionize all human relations. I am convinced that this wonder can and will be accomplished in time to come.

I may add that I have devoted much thought to the solution of the problem. I have managed to reflect such a picture, which I have seen in my mind, to the mind of another person, in another room.

To free myself of these tormenting appearances, I tried to concentrate my mind on something else I had seen, and in this way, I would often obtain temporary relief; but in order to get it I had to conjure continuously new images.

It was not long before I found that I had exhausted all of those at my command; my "reel" had run out as it were, because I had seen little of the world -only objects in my home and the immediate surroundings.

As I performed these mental operations for the second or third time, in order to chase the appearances from my vision, the remedy gradually lost all its force. Then instinctively commenced to make excursions beyond the limits of the small world of which I had knowledge, and I saw new scenes.

These were at first very blurred and indistinct, and would flit away when I tried to concentrate my attention upon them. They gained in strength and distinctness and finally assumed the concreteness of real things.

I soon discovered that my best comfort was attained if I simply went on in my vision further and further, getting new impressions all the time, and so I began to travel; of course, in my mind. Every night, (and sometimes during the day), when alone, I would start on my journeys, see new places, cities and countries; live there, meet people and make friendships and acquaintances and, however unbelievable, it is a fact that they were just as dear to me as those in actual life, and not a bit less intense in their manifestations.

This I did constantly until I was about seventeen, when my thoughts turned seriously to invention. Then I observed to my delight that I could visualize with the greatest facility. I needed no models, Drawings or experiments. I could picture them all as real in my mind.

Thus, I have been led unconsciously to evolve what I consider a new method of materializing inventive concepts and ideas, which is radially opposite to the purely experimental and is in my opinion ever so much more expeditious and efficient.

The moment one constructs a device to carry into practice a crude idea, he finds himself unavoidably engrossed with the details of the apparatus. As he goes on improving and reconstructing, his force of concentration diminishes and he loses sight of the great underlying principle.

Results may be obtained, but always at the sacrifice of quality. My method is different. I do not rush into actual work. When I get an idea, I start at once building it up in my imagination. I change the construction, make improvements and operate the device in my mind.

It is absolutely immaterial to me whether I run my turbine in thought or test it in my shop. I even note if it is out of balance. There is no difference whatever; the results are the same.

In this way I am able to rapidly develop and perfect a conception without touching anything. When I have gone so far as to embody in the invention every possible improvement I can think of and see no fault anywhere, I put into concrete form this final product of my brain. Invariably my device works as I conceived that it should, and the experiment comes out exactly as I planned it.

In twenty years, there has not been a single exception. Why should it be otherwise? Engineering, electrical and mechanical, is positive in results. There is scarcely a subject that cannot be examined beforehand, from the available theoretical and practical data.

The carrying out into practice of a crude idea as is being generally done, is, I hold, nothing but a waste of energy, money, and time. My early affliction had however, another compensation. The incessant mental exertion developed my powers of observation and enabled me to discover a truth of great importance.

I had noted that the appearance of images was always preceded by actual vision of scenes under peculiar and generally very exceptional conditions, and I was impelled on each occasion to locate the original impulse.

After a while this effort grew to be almost automatic and I gained great facility in connecting cause and effect. Soon I became aware, to my surprise, that every thought I conceived was suggested by an external impression. Not only this but all my actions were prompted in a similar way.

In the course of time it became perfectly evident to me that I was merely an automation endowed with power of movement responding to the stimuli of the sense organs and thinking and acting accordingly.

The practical result of this was the art of "teleautomatics" which has been so far carried out only in an imperfect manner. Its latent possibilities will, however be eventually shown. I have been years planning self-controlled automata and believe that mechanisms can be produced which will act as if possessed of reason, to a limited degree, and will create a revolution in many commercial and industrial departments.

I was about twelve years of age when I first succeeded in banishing an image from my vision by willful effort, but I never had any control over the flashes of light to which I have referred. They were, perhaps, my strangest and [most] inexplicable experience.

They usually occurred when I found myself in a dangerous or distressing situation or when I was greatly exhilarated. In some instances, I have seen all the air around me filled with tongues of living flame. Their intensity, instead of diminishing, increased with time and seemingly attained a maximum when I was about twenty-five years old.

While in Paris in 1883, a prominent French manufacturer sent me an invitation to a shooting expedition which I accepted. I had been long

confined to the factory and the fresh air had a wonderfully invigorating effect on me.

On my return to the city that night, I felt a positive sensation that my brain had caught fire. I was a light as though a small sun was located in it and I passed the whole night applying cold compressions to my tortured head.

Finally, the flashes diminished in frequency and force but it took more than three weeks before they wholly subsided. When a second invitation was extended to me, my answer was an emphatic NO!

These luminous phenomena still manifest themselves from time to time, as when a new idea opening up possibilities strikes me, but they are no longer exciting, being of relatively small intensity. When I close my eyes I invariably observe first, a background of very dark and uniform blue, not unlike the sky on a clear but starless night.

In a few seconds this field becomes animated with innumerable scintillating flakes of green, arranged in several layers and advancing towards me. Then there appears, to the right, a beautiful pattern of two systems of parallel and closely spaced lines, at right angles to one another, in all sorts of colors with yellow, green, and gold predominating.

Immediately thereafter, the lines grow brighter and the whole is thickly sprinkled with dots of twinkling light. This picture moves slowly across the field of vision and in about ten seconds vanishes on the left, leaving behind a ground of rather unpleasant and inert grey until the second phase is reached.

Every time, before falling asleep, images of persons or objects flit before my view. When I see them I know I am about to lose consciousness. If they are absent and refuse to come, it means a sleepless night.

During this period, I contracted many strange likes, dislikes and habits, some of which I can trace to external impressions while others are unaccountable. I was fascinated with the glitter of crystals, but pearls would almost give me a fit.

After finishing the studies at the Polytechnic Institute and University, I had a complete nervous breakdown and, while the malady lasted, I observed many phenomena, strange and unbelievable."

WAS TESLA ACTUALLY AN ALIEN?

In her book *Return of the Dove*, Margaret Storm states that Tesla was not an earth man. She says that the space people related that a male child was born on board a spaceship which was on a flight from Venus to the earth in July, 1856.

The little boy was called Nikola. The ship landed at midnight, between July 9 and 10, in a remote mountain province in what is now Croatia. There, according to prior arrangements, the child was placed in the care of a good man and his wife, the Rev. Milutin and Djouka Tesla.

Supposedly, the space people released this information in 1947 to Arthur H. Matthews of Quebec, Canada.

ALIEN SIGNALS IN THE NIGHT:

Arthur H. Matthews was an electrical engineer who from boyhood was closely associated with Tesla. Matthews claimed that Tesla entrusted him with many tasks, including the Tesla interplanetary communications set that was first conceived in 1901, with the objective of communicating with the planet Mars. Tesla had suggested that he could transmit through the earth and air, great amounts of power to distances of thousands of miles.

"I can easily bridge the gulf which separates us from Mars, and send a message almost as easily as to Chicago."

Due to pressures of other research at the time, the first working model was not built by Tesla until 1918.

In 1899, Nikola Tesla, with the aid of his financial backer, J.P. Morgan, set up at Colorado Springs an experimental laboratory containing high voltage radio transmission equipment. The lab had a 200-ft. tower for transmission and reception of radio waves and the best receiving equipment available at the time.

One night, when he was alone in the laboratory, Tesla observed what he cautiously referred to as electrical actions which definitely appeared to be intelligent signals. The changes were taking place periodically and with such a clear suggestion of number and order that they could not be traced to any cause then known to him.

Tesla elaborated on the subject of Talking With the Planets in Collier's Weekly (March 1901):

"As I was improving my machines for the production of intense electrical actions, I was also perfecting the means for observing feeble efforts. One of the most interesting results, and also one of great practical importance, was the development of certain contrivances for indicating at a distance of many hundred miles an approaching storm, its direction, speed and distance traveled.

"It was in carrying on this work that for the first time I discovered those mysterious effects which have elicited such unusual interest. I had perfected the apparatus referred to so far that from my laboratory in the Colorado mountains I could feel the pulse of the globe, as it were, noting every electrical change that occurred within a radius of eleven hundred miles.

"I can never forget the first sensations I experienced when it dawned upon me that I had observed something possibly of incalculable consequences to mankind. I felt as though I were present at the birth of a new knowledge or the revelation of a great truth... My first observations positively terrified me, as there was present in them something mysterious, not to say supernatural, and I was alone in my laboratory at night; but at

that time the idea of these disturbances being intelligently controlled signals did not yet present itself to me.

"The changes I noted were taking place periodically and with such a clear suggestion of number and order that they were not traceable to any cause known to me. I was familiar, of course, with such electrical disturbances as are produced by the sun, Aurora Borealis, and earth currents, and I was as sure as I could be of any fact that these variations were due to none of these causes.

"The nature of my experiments precluded the possibility of the changes being produced by atmospheric disturbances, as has been rashly asserted by some. It was sometime afterward when the thought flashed upon my mind that the disturbances I had observed might be due to an intelligent control.

"Although I could not at the time decipher their meaning, it was impossible for me to think of them as having been entirely accidental. The feeling is constantly growing on me that I had been the first to hear the greeting of one planet to another. A purpose was behind these electrical signals"

This incident was the first of many in which Tesla intercepted what he felt were intelligent signals from space.

At the time, it was surmised by prominent scientists that Mars would be a likely haven for intelligent life in our solar system, and Tesla at first thought these signals may be originating from the red planet. He would later change this viewpoint as he became more adept at translating the mysterious signals. Near the end of his life, Tesla had developed several inventions that allegedly could send powerful amounts of energy to other planets.

In 1937, during one of his birthday press conferences, Tesla announced:

"I have devoted much of my time over the years to the perfecting of a new small and compact apparatus by which energy in considerable

amounts can now be flashed through interstellar space to any distance without the slightest dispersion."

(New York Times, July 11, 1937.)

Tesla never publicly revealed the technical details of his improved transmitter, but in his 1937 announcement, he revealed a new formula showing that,

"The kinetic and potential energy of a body is the result of motion and determined by the product of its mass and the square of its velocity. Let the mass be reduced, the energy is reduced by the same proportion. If it be reduced to zero, the energy is likewise zero for any finite velocity."

(New York Sun, July 12, 1937, pg. 6.)

A FEAR OF ALIENS:

In the Tesla journals that he uncovered, Dale Alfrey noted that by the 1920's Tesla had grown confident that he was able to make sense of the strange radio broadcasts from space. However, soon afterwards, Tesla began to expressed great concerns about beings from other planets who had unsavory designs for planet Earth.

"The signals are too strong to have traveled the great distances from Mars to Earth," wrote Tesla. "So, I am forced to admit to myself that the sources must come from somewhere in nearby space or even the moon. I am certain however, that the creatures that communicate with each other every night are not from Mars, or possibly from any other planet in our solar system."

Several years after Tesla announced his reception of signals from space, Guglielmo Marconi also claimed to have heard from an alien radio transmitter. However, Marconi was just as quickly dismissed by his contemporaries, who claimed that he had received interference from another radio station on Earth.

There is some public confirmation in the validity of the lost journals and Tesla's belief in extraterrestrials and the importance of communicating with them. As noted earlier, Arthur H. Mathews claimed that Tesla had secretly developed the Teslascope for the purpose of communicating with aliens. The late Dr. Andrija Puharich interviewed Mathews for the Pyramid Guide, May-June & July-Aug. 1978. This interview revealed for the first-time Mathews connections to Tesla.

Arthur Mathews was born in England and his father was a laboratory assistant to the noted physicist Lord Kelvin back in the 1890s. Tesla came over to England to meet Kelvin... to convince him that Alternating Current was more efficient than Direct Current. Kelvin at that time opposed the AC movement.

In 1902, the Mathews family left England and immigrated to Canada. When Mathews was 16 his father arranged for him to apprentice under Tesla. He eventually worked for him and continued this alliance until Tesla's death in 1943.

"It's not generally known, but Tesla actually had two huge magnifying transmitters built in Canada," Mathews said.

"I operated one of them. People mostly know about the Colorado Springs transmitters and the unfinished one on Long Island. I saw the two Canadian transmitters. All the evidence is there."

Mathews stated that the Teslascope is the thing Tesla invented to communicate with beings on other planets. There's a diagram of the Teslascope in Mathews book, The Wall of Light.

"In principle, it takes in cosmic ray signals," Mathew's said.

"Eventually the signals are stepped down to audio. Speak into one end, and the signal goes out the other end as a cosmic ray emitter."

Mathews' diagrams of the Teslascope make little electronic sense. No one has ever confirmed the reality of the device. Mathews claims,

however, that he built a model Tesla Interplanetary Communications Set in 1947 and operated it successfully.

He suggested that due to the sets limited range, he was only able to contact spacecraft operating near the earth. He had hoped to someday build a set capable of communicating directly to the planets.

"Tesla had told me that beings from other planets were already here," related Matthews. "He was very afraid that they had been controlling man for thousands of years and that we were simply test subjects for an experiment of extremely long duration."

Matthews did not share in Tesla's convictions that aliens may not have the Earth's best interests in mind. His opinion was that if extraterrestrials were so advanced as to be able to travel from solar system to solar system, then they must also be socially advanced and peace-loving.

Matthews eagerness to continue experimenting with the Teslascope was indicative of the early days of the so-called "modern UFO era." By the 1950's, contactees such as George Adamski and Howard Menger were writing books and lecturing to eager believers about the almost god-like space brothers.

These UFO occupants claimed to be from almost every planet in the solar system, with Venus and Mars being especially favored. The space brothers preached a form of "New Age Space Religion," with Utopian descriptions of their home worlds and denouncement of mankind's warlike ways.

Tesla would certainly have felt vindicated by his earlier claims if he had lived long enough to experience the modern UFO era. He mentions in his journals his frustrating attempts to interest those in the government or military about his theories. Apparently, Tesla's letters went unanswered - the question remains whether or not his ideas were seriously considered or if he was thought of as simply a crackpot.

Circumstantial evidence points to a certain amount of expectation by the United States when the first UFOs were sighted during WWII. It could be

that Tesla's ideas had more impact, albeit secretly, than Tesla ever imagined.

UFOs AND ELECTROGRAVITY PROPULSION:

Did Tesla Discover the Secrets of Antigravity?

Nikola Tesla has been credited for the creation of much of the technology that we take for granted today. Without the genius of Tesla, we would not have radio, television, AC electricity, Tesla coil, fluorescent lighting, neon lighting, radio control devices, robotics, x-rays, radar, microwaves and

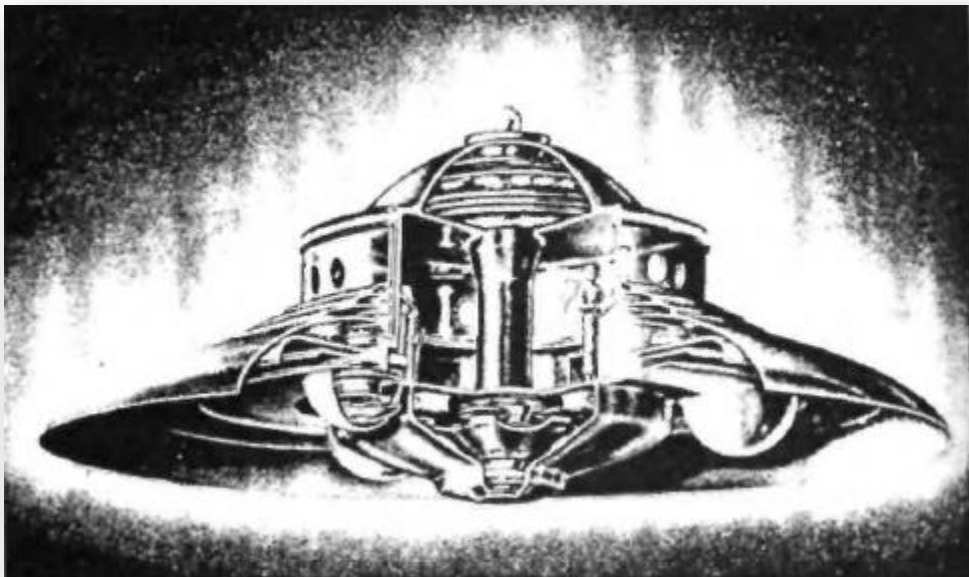

dozens of other amazing inventions.

Because of this, it is no surprise that Tesla also delved into the world of flight and possibly, antigravity. In fact, his last patent in 1928 ([#1,655,114](#)), was for a flying machine that resembled both a helicopter and an airplane. Before he died, Tesla reportedly devised plans for the engine of a spaceship. He called it the anti-electromagnetic field Drive or Space Drive.

The usual Tesla birthday announcement -on his 79th birthday (1935) -Tesla made a brief reference to the theory saying it applies to molecules and atoms as well as to the largest heavenly bodies, and to "... all matter in the universe in any phase of its existence from its very formation to its ultimate disintegration."

A lecture Tesla prepared for the Institute of Immigrant Welfare (May. 12, 1938), dealt with his Dynamic Theory of Gravity. Tesla said in his lecture that this was:

"One of two far reaching discoveries, which I worked out in all details in the years 1893 and 1894."

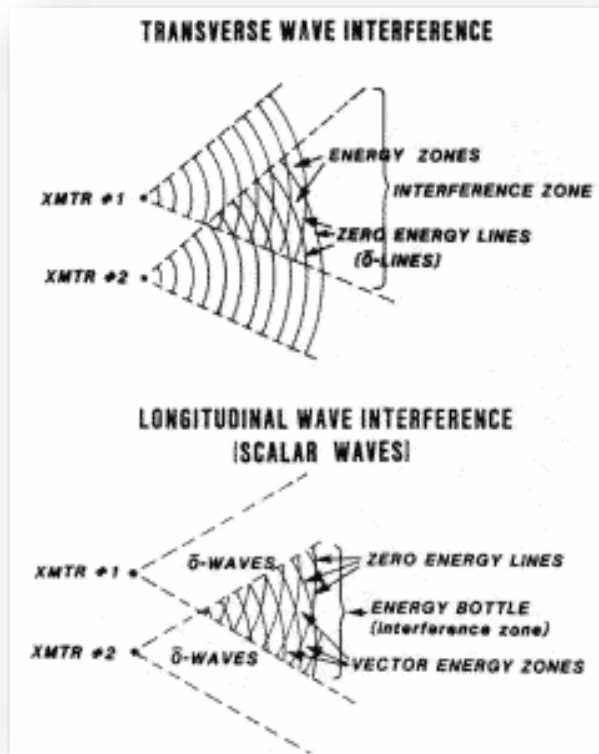

In his 1938 lecture, Tesla said he was progressing with the work, and hoped to give the theory to the world very soon.

The two great discoveries to which Tesla referred, were:

1. The Dynamic Theory of Gravity - which assumed a field of force which accounts for the motions of bodies in space; assumption of this field of force dispenses with the concept of space curvature (ala Einstein); the ether has an indispensable function in the phenomena (of universal gravity, inertia, momentum, and movement of

heavenly bodies, as well as all atomic and molecular matter).

2.Environmental Energy - the Discovery of a new physical Truth: there is no energy in matter other than that received from the environment. (Which goes against Einstein's $E=mc^2$).

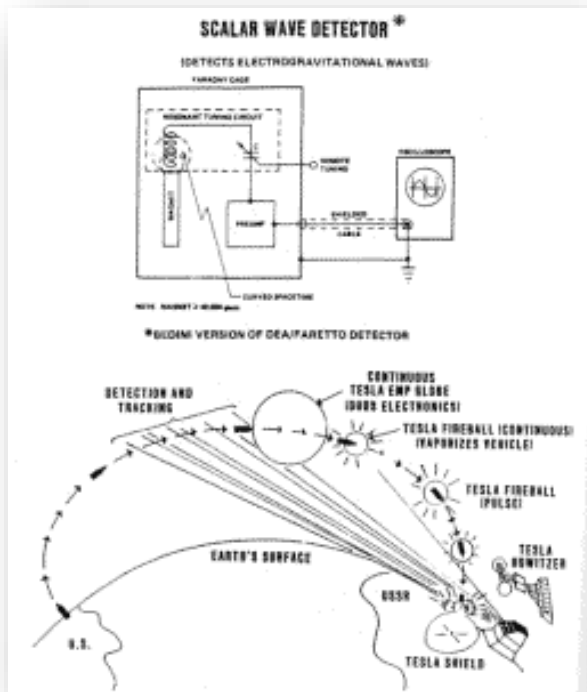

In an article, "Man's Greatest Achievement", Tesla outlined his Dynamic Theory of Gravity by saying that the luminiferous ether fills all space.

The ether is acted upon by the life-giving creative force and is thrown into "infinitesimal whirls" ("micro helices") at near the speed of light, becoming ponderable matter. When the force subsides and motion ceases, matter reverts to the ether (a form of "atomic decay").

Man can harness these processes to:

- Precipitate matter from the ether.
- Create whatever he wants with the matter and energy derived.
- Alter the earth's size. Control earth's seasons (weather control).
- Guide earth's path through the Universe, like a spaceship.
- Cause the collisions of planets to produce new suns and stars, heat, and light.
- Originate and develop life in infinite forms.

In the 1980s he was proved to be right. A study of energy loss in a double neutron star pulsar called PSR 1913 + 16 proved that gravity waves exist.

Tesla's idea that gravity is a field effect is now taken more seriously than Einstein took it.

While researching Tesla's statements, it was discovered that more complete statements concerning these discoveries could only be gleaned from scattered and sparse sources, because Tesla's papers are concealed in government vaults for national security reasons.

When an investigator specifically asked for these papers at the National Security Research Center (now the Robert J. Oppenheimer Research Center) in 1979, he was denied access because they were still classified.

HOW TO BUILD A FLYING SAUCER:

Tesla had discovered that the electrostatic emission from the surface of a conductor will always concentrate where the surface curves or even presents an edge. The sharper the curve or edge, the greater the concentration of electron emission. Tesla also observed that an electrostatic charge will flow over the surface of a conductor rather than penetrate it. This is called the Faraday or Skin Effect, discovered by Michael Faraday many years ago.

This also explains the principles of the Faraday Cage which is used in high voltage research labs to protect humans and electrosensitive equipment from harm. According to eyewitness reports of interiors of UFOs, there is a circular column or channel through the center of the vehicle.

This reportedly serves as a superstructure for the rest of the saucer shaped vehicle, and also carries a high voltage, high frequency coil. It is believed to be a resonant transformer which gives the electrostatic and electromagnetic charge to the craft and establishes polarity.

This coil is relative to what is known as a Tesla coil. The Tesla Coil of course, was invented by Tesla in 1891. This column or channel is approximately two feet in diameter and is hollow. On some vehicles, this hollow area has a turbine generator in it.

When the vacuum is created on one hemisphere of the craft, the atmospheric pressure is allowed to rush through the tube to Drive a sort of turbine electrical generator. Some reports say the extraterrestrials use this system as stationary power plants for electrical energy on their planets as well.

The eyes of the craft are arranged by electro-optic lenses placed at quadrants or wherever they wish to see from. The screen-like monitors are placed on a console where the navigator can observe all areas around and about the vehicle at the same time. This includes the magnification lenses which are used without changing positions.

There are also windows about elbow level and about one foot through or thick. This distance would have to be in view of the four or more walls or plates of the capacitor hulls making up the major portion of the craft. The windows have an iris type of shutter so that when it is closed, it allows electrostatic charge to flow evenly.

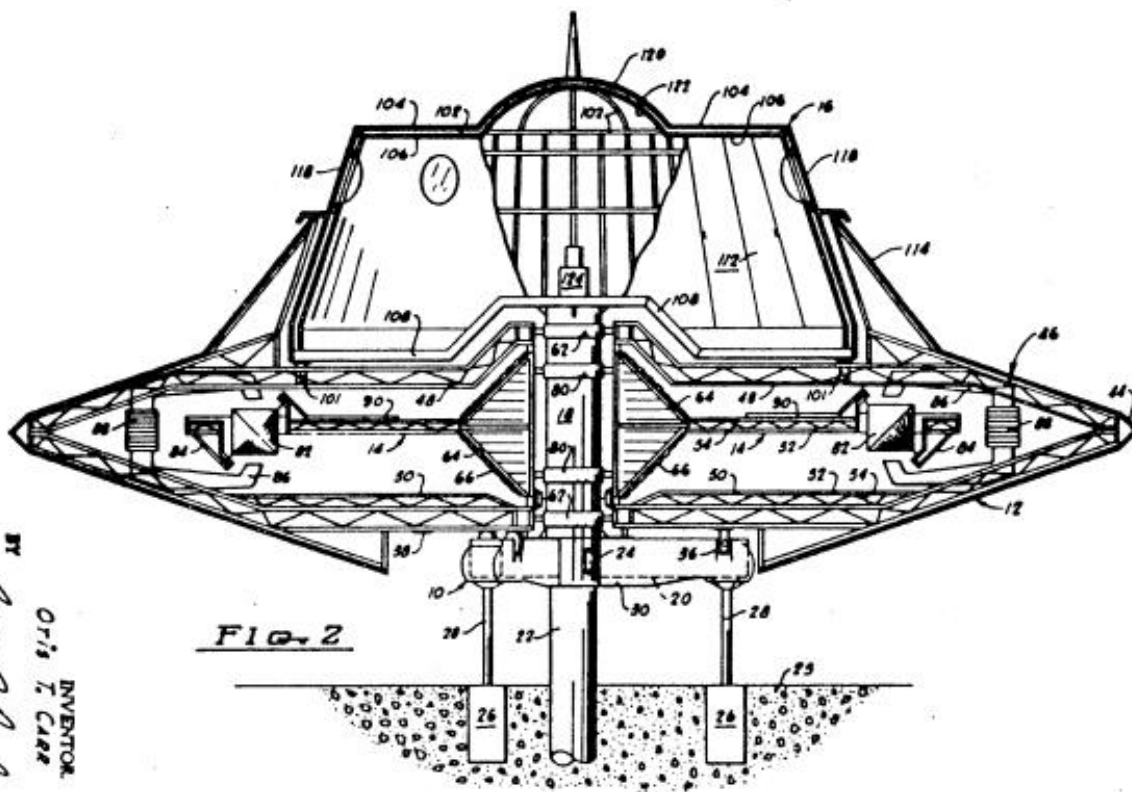

BY *George J. Carr*
 O-T'S T. CARR
 INVENTOR
 ATTORNEY

Nov. 10, 1959
 Filed Jan. 22, 1959
 O. T. CARR
 AIRCRAFT DEVICE
 2,912,244
 5 Sheets-Sheet 2

Dr. T. Townsend Brown - UFO Propulsion, Electrogravitics:

Did we discover the secrets of alien UFO propulsion?

Headed by Dr. TT Brown, Project Winterhaven was the start of the first Black Ops Project. It was a partnership between industry and government to create craft which used field propulsion to nullify the effects of gravitational forces.

FIRST, AN EXPLANATION OF "ELECTROGRAVITICS" IS PROBABLY IN ORDER:

It is the science of using high voltage electricity to provide propulsive force to aircraft or spacecraft of certain geometries. "The plane or spaceship is pulled along by its self-generated gravity field, like a surfer riding a wave." And, through the investigative effort of Dr. Paul LaViolette, it has become clear that electrogravitics became an integral part of the B-2 Stealth Bomber, giving it an unlimited range.

The idea of using high voltage electricity as a means of propulsion is not new. Tesla laid the groundwork in the late 19th century which was then continued by such notables as Thomas Townsend Brown, who discovered in 1923 what was later called the Biefeld-Brown Effect.

Thomas Townsend Brown noticed that when he had two plates carrying high voltages of direct current separated by a dielectric, the negative electrode moved by itself in the direction of the positive plate. In other words, Townsend Brown discovered that it is possible to create an artificial gravity field by charging an electrical capacitor to a high-voltage.

He built a special capacitor which utilized a heavy, high charge-accumulating (high K-factor) dielectric material between its plates and found that with charges between 70,000 to 300,000 volts, it would move in the direction of its positive pole. When oriented with its positive side up, it would proceed to lose about one percent of its weight.

He attributed this motion to an electrostatically-induced gravity field acting between the capacitors oppositely charged plates. By 1958, he had succeeded in developing a 15-inch diameter model saucer that could lift over 110% of its weight. Brown's experiments had launched a new field of investigation which came to be known as Electrogravitics, the technology of controlling gravity through the use of high-voltage electric charge.

As early as 1952, an Air Force major general witnessed a demonstration in which Brown flew a pair of 18-inch disc airfoils suspended from opposite ends of a rota-table arm. When electrified with 50,000 volts, they circuited at a speed of 12 miles per hour.

About a year later, he flew a set of 3-foot diameter saucers for some Air Force officials and representatives from a number of major aircraft companies. When energized with 150,000 volts, the discs sped around the 50-foot diameter course so fast that the subject was immediately classified.

Interavia magazine later reported that the discs could attain speeds of several hundred miles per hour when charged with several hundred thousand volts. Brown's discs were charged with a high positive voltage, on a wire, running along their leading edge and a high negative voltage, on a wire, running along their trailing edge

As the wires ionized the air around them, a dense cloud of positive ions would form ahead of the craft and corresponding cloud of negative ions would form behind the craft. Brown's research indicated that, like the charged plates of his capacitors, these ion clouds induced a gravitational force directed in the minus to plus direction.

As the disc moved forward in the response to its self-generated gravity field, it would carry with it its positive and negative ion clouds and their associated electrogravity gradient. Consequently, the discs would ride their advancing gravity wave much like surfers ride an ocean wave.

Dr. Mason Rose, one of Townsend's colleagues, described the disc's principle of operation as follows:

"The saucers made by Brown have no propellers, no jets, no moving parts at all. They create a modification of the gravitational field around themselves, which is analogous to putting them on the incline of a hill.

They act like a surfboard on a wave... the electrogravitational saucer creates its own hill, which is a local distortion of the gravitational field, then it takes this hill with it in any chosen direction and at any rate.

"The occupants of one of [Brown's] saucers would feel no stress at all no matter how sharp the turn or how great the acceleration. This is because the ship and its occupants and the load are all responding equally to the wave-like distortion of the local gravitation field."

(Does this explain how UFO occupants can handle the sharp turns and high speeds that have been observed?)

Although skeptics at first thought that the discs were propelled by more mundane effects such as the pressure of negative ions striking the positive electrode. Brown later carried out vacuum chamber tests which proved that a force was present even in the absence of such ion thrust.

He did not offer a theory to explain this unconventional electrogravitic phenomenon; except to say that it was predicted neither by general relativity nor by modern theories of electromagnetism. However, recent advances in theoretical physics provide a rather straightforward explanation of the principle.

According to the novel physics of subquantum kinetics, gravity potential can adopt two polarities, instead of one. Not only can a gravity field exist in the form of a matter-attracting gravity potential well, as standard physics teaches, but it can also exist in the form of a matter repelling gravity potential hill.

Moreover, it predicts that these gravity polarities should be directly matched with electrical polarity; positively charged particles such as

protons generating gravity wells and negatively charged particles such as electrons generating gravity hills.

Thus, contrary to conventional theory, the electron produces a matter-repelling gravity field. Electrical neutral matter remains gravitationally attractive because the proton's G-well marginally dominates the electron's G-hill. Consequently, subquantum kinetics predicts that the negative ion cloud behind Brown's disc should form a matter repelling gravity hill while the positive ion cloud ahead of the disc should form a matter attracting gravity well.

As increasing voltage is applied to the disc, the gravity potential hill and well become increasingly prominent and the gravity potential gradient between them increasingly steep. In Dr. Rose's terminology, the craft would find itself on the incline of a gravitational hill, since gravity force is known to increase in accordance with the steepness of such a gravity potential slope, increased voltage would induce an increasingly strong gravity force on the disc and would act in the direction of the positive ion cloud. The disc would behave as if it was being tugged by a very strong gravitational field emanating from an invisible planet sized mass positioned beyond its positive pole.

Early in 1952 Brown had put together a proposal, code named Project Winterhaven, which suggested that the military developed an antigravity combat saucer with Mach-3 capability. The 1956 intelligence study entitled "Electrogravitics Systems - An Explanation of Electrostatic Motion, Dynamic Counterbary and Barycentric Control", prepared by the private aviation intelligence firm, Aviation Studies International Ltd., indicates that as early as November 1954 the Air Force had begun plans to fund research that would accomplish Project Winterhaven's objectives.

The study, originally classified "Confidential," mentions the name of more than ten major aircraft companies which were actively involved in the electrogravitics research in an attempt to duplicate or extend Brown's

seminal work. Additional information is to be found in another aviation intelligence report entitled: The "Gravitics Situation."

Unfortunately, due to the military's TOP SECRET classification, Townsend Brown's work has not appeared in any physics or science publications that can be accessed.

ARTICLE REVEALS GOVERNMENT RESEARCH:

Because of the influence of such pioneers as Tesla and T. Townsend Brown, the research and development of antigravity devices has been ongoing for a number of years. The June 1957 issue of *Mechanic's Illustrated* featured an article by G. Harry Stine entitled: Conquest of Space. Stine, the Chief of Navy Range Operations at White Sands Proving Grounds, makes it perfectly clear that the military was extremely interested in antigravity research.

There is a good chance that the rocket will eventually become obsolete for space travel. Recent discoveries indicate that the spaceship of the future may be powered by anti-gravity devices. These, instead of using brute force to overcome gravity, will use the force of gravity itself much as an airplane uses the air to make it fly.

(Don't tell anyone, but our secret space program is already using alien technology to travel this galaxy with manned space ships. The rockets are mostly for show to justify the hefty NASA expenditures.)

Although much of this may still be classified, scientists have built disc airfoils two feet in diameter incorporating a variation of the simple two-plate electrical condenser (capacitor), which charged to a potential of 50,000 volts, has achieved a speed of seventeen feet per second with a total energy input of fifty watts.

A three-foot diameter disc airfoil charged to 150 Kilovolts turned out such an amazing performance that the whole thing was immediately classified. Flame-jet generators, making use of the electrostatic charge discovered

in rocket exhausts, have been developed which will supply charges up to 15 million volts.

Several important things have been discovered with regard to gravity propulsion. For one, the propulsive force doesn't act on only one part of the ship it is pushing; it acts on all parts within the gravity field created by the gravitic Drive. And It probably is not limited to the speed of light.

Gravity-powered vehicles have apparently changed direction, accelerated rapidly at very high g's and stopped abruptly without any heavy stresses being experienced by the measuring devices aboard the vehicle and within the gravity-propulsion field. This control is done by changing the direction, intensity and polarity of the charge on the condenser plates of the Drive unit, a fairly simple task for scientists.

LEVITATION SECRETS REVEALED

Sir William Crookes, the English scientist who developed the cathode-ray tube we now use for television, made extensive investigations of levitation phenomena -a field that once belonged to vaudeville magicians. Scientists, reasoning that if they believed his reports of weird green glows in vacuum tubes they should also look into Crookes' levitation studies, have been making slow but steady progress. Others have been investigating the fields of gravitic isotopes, jet electron streams, and the mechanics of the electron shells of atoms.

AND EVEN ELECTRICAL WAVES WHICH LINK ELECTRICITY AND GRAVITY!

We are quickly licking the problems of gravity. Indications are that we are on the verge of tapping a brand-new group of electrical waves which link electricity and gravity.

Now, gravity researchers seem to think that the condenser will open up the science of electrogravitics. Soon we may be able to eliminate gravity as a structural, dynamic and medical problem.

Remember, we now have capabilities, with gravitic spaceships, to travel to the moon in less than an hour, to the planets in less than a day or to the stars themselves in a matter of months. And even able to do it in absolute comfort without the problems of zero-gravity or high accelerations.

(And we are doing these things now, except it's supposed to be a secret, so don't tell anyone I mentioned it!)

AND ALL THIS STUFF THAT WE ARE NOT ALLOWED TO USE, EVEN THOUGH OUR MONEY PAID FOR IT!

Guess we have been in the alien propulsion age for a long time, and we didn't know it! No one has told us about the miraculous technologies that we possess. Just imagine what could be done to clean up this planet and save lives with technologies that have already been made to work, but huge sums of money are being spent to keep them locked up and out of our sight!

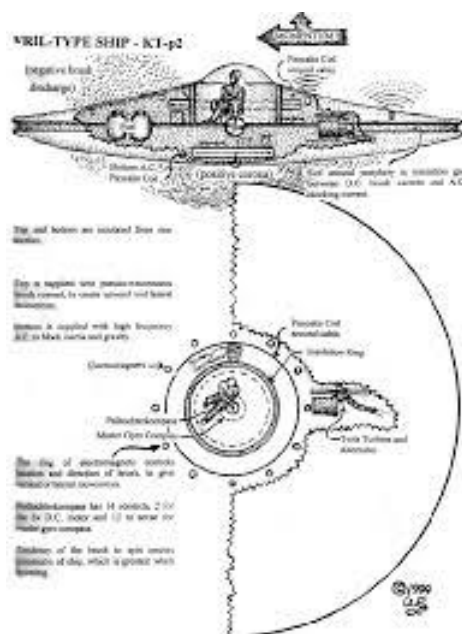

The B-2 aircraft has mastered the ability to control gravity!

Is Antigravity Already in Use?

Recently an article appeared in Jane's Aviation Weekly that stated the B-2 Stealth Nuclear-Strike Bomber is in fact, currently using an electrogravitic propulsion system.



B-2 Stealth Bomber

Paul A. LaViolette has done considerable study on the use of electrogravitic technology by the U.S. Air Force, which has conducted secret Black Project research on the matter since late 1954.

LaViolette contends that electrogravitics may have been put to practical use in the B-2 Advanced Technology Bomber to provide an exotic auxiliary mode of propulsion. This conclusion is based on the recent disclosure that the B-2 charges both its wing leading edge and jet exhaust stream to a high voltage.

Positive ions emitted from its wing leading edge would produce a positively charged parabolic ion sheath ahead of the craft while negative ions injected into its exhaust stream would set up a trailing negative space charge with a potential difference in excess of 15 million volts.

According to electrogravitic research carried out by Tesla and T. Townsend Brown, such a differential space charge would set up an artificial gravity field that would induce a reactionless force on the aircraft in the direction of the positive pole.

An electrogravitic Drive of this sort could allow the B-2 to function with over-unity propulsion efficiency when cruising at supersonic velocities.

Those familiar with the research of Tesla in the early 20th century will quickly realize that this is tantamount to stating that the B-2 is able to function as an antigravity aircraft. Aviation Week obtained their information about the B-2 from a small group of renegade west coast scientists and engineers who were formerly associated with black op research projects.

In making these disclosures, these scientists broke a code of silence that rivals the Mafia's. They took the risk because they felt that it was important for economic reasons that efforts be made to declassify certain black op technologies for commercial use.

Two of these individuals said that their civil rights had been blatantly abused (in the name of security) either to keep them quiet or to prevent them from leaving the tightly controlled black op research and development community. Although the scientists mentioned nothing about electrogravitics in their Aviation Week disclosure about the B-2, they

did admit to the existence of very dramatic, classified technologies applicable to aircraft control and propulsion.

They were especially hesitant to discuss these projects, noting that they are very secret. One of them commented:

"Besides, it would take about 20 hours to explain the principles, and very few people would understand them anyway."

Apparently, what he meant is that this aircraft control and propulsion technology is based on principles that go beyond what is currently known and understood by most academic physicists. That is with the exception of two geniuses who developed the original ideas for high voltage electric drives decades ago.

It must also be revealed that the B-2 is now no longer the only aircraft to use such technologies. Since that time an entire generation of black budget secret aircraft has been developed with electrogravitic systems.

**Gravitational field propulsion allows
ACCELERATIONS AT 100 G'S OR GREATER WITHOUT
HARMING THE OCCUPANTS for trips to the moon in
20 minutes & stars in a few days.**

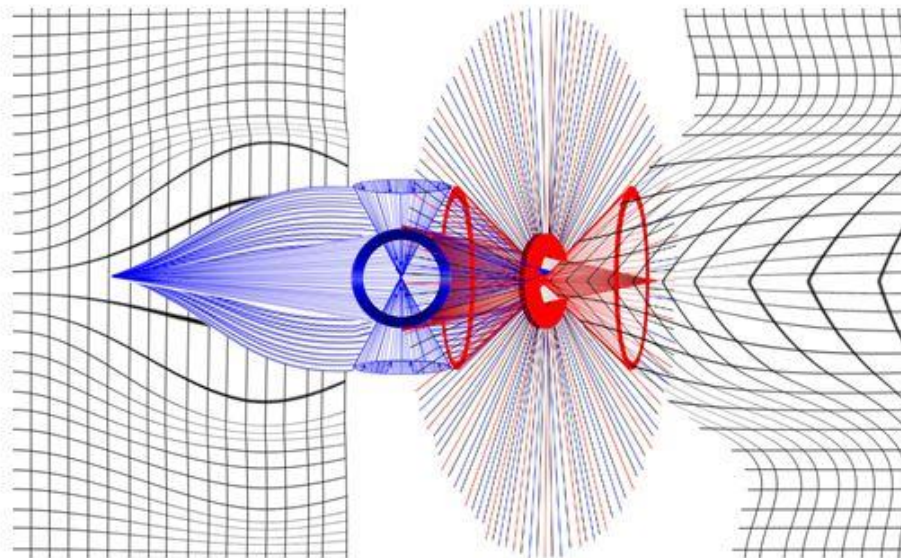

**Craft propelled by gravitational field propulsion can
propel themselves, change colors & cloak.**

Art Bell's Mysterious Metal - And the Key to Antigravity

The suggestion that UFOs could be manmade flying machines using exotic technologies is not new to the study of unidentified flying objects. In the 1950's several researchers in Europe claimed that Tesla and Marconi had secretly built and tested operational antigravity aircraft. Using electrogravitic drives, these experimental aircraft were eventually based out of a secret location in South America.

Allegedly, Nazi Germany got a hold of this technology and produced several antigravity flying saucers of their own. Fortunately, by the time Hitler decided to dedicate more time and funds to the Nazi flying saucer project, the war was almost over for the Germans. And by that time Tesla had passed away, but it is almost certain that he would have been horrified by the use of his invention by the Germans.

Early evidence for these anecdotal tales was scant and consisted almost entirely of discovered research papers and a few photos of similarly shaped UFOs. Early UFO contactees such as George Adamski and Howard Menger witnessed and even photographed UFOs that bore a striking resemblance to the small discs built by T. Townsend Brown.

Could these UFOs actually be manmade machines flown by humans? Or were extraterrestrials flying around in spacecraft utilizing similar technology as that discovered by Tesla and Brown?

In 1996, late night radio host Art Bell received a package containing bits of metal that the sender claimed was taken from the crashed UFO found near Roswell, New Mexico in 1947. Could these unassuming pieces of metal be the evidence that proved the reality of UFOs and their use of electrogravitic technology? The pieces of metal seemed almost too good to be true and Bell was at first skeptical because of similar past hoaxes involving alleged parts from UFOs.

Bell sent a few samples to Linda Moulton Howe, who promptly had the metal analyzed. Using Wave Dispersive Spectroscopy, it was discovered

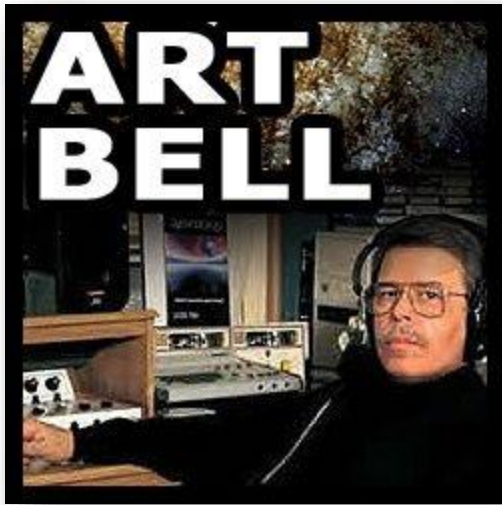

that the metal was made up of a magnesium zinc alloy with pure bismuth layers. There was a range from 97 to about 97 -1/2 % magnesium and 3% to 2 -1/2 % zinc in each of those 100 to 200 micron layers of the magnesium zinc, so the metal was almost entirely magnesium with about 3% zinc.

The pure bismuth layers were one to four microns thick in a slightly wavy pattern and nothing else but bismuth was found. No oxygen was found, no zirconium, no other elements, just these three.

High energy experiments conducted on the unusual metal indicated a tendency for lateral movement. Unfortunately, this research has not resulted in any solid conclusions at this time.

After this information was broadcast on Art's show, Howe received a fax from a listener named Dan who indicated he had professional knowledge that would relate the material to antigravity. He had worked from 1973 to 1980 for an organization called Aeronautical Systems Division at Edwards Air Force Base in California with some assignments at Wright Patterson in Ohio.

Dan received a bachelors degrees in physics, aerospace engineering and computer science from California Polytechnic State University, masters degrees in computer science and aerospace engineering from the University of California at Berkley and then received his Ph.D. in physics in 1974 after he had already begun work as a civilian scientist for the Air Force.

Dan told Howe that he had been involved in aeronautical engineering and evaluations when he first saw metal similar to what was sent to Art bell. The metal supposedly was used in a electrogravitic capacity.

In the case of bismuth, it is basically a diamagnetic material which means it tends to repel a magnetic field.

"There were very strange things that were bound with bismuth as basically positive charges were added to it, you know, putting a field, a positive electron field into the bismuth," Dan said to Howe.

"As a matter of fact, they were very dramatic, some of the things that they found. A lot of this goes all the way back to 1917 with Nikola Tesla and his discoveries of electrical fields and gravity."

Howe wanted to know what was the most dramatic thing that would happen as the positive flow was increased into bismuth. Dan's answer was that basically there would be a mass reduction to the point where it could come to zero and actually rise into the air, creating a lifting body.

[IS THIS SECRET OF THE UFOs?](#)

A now defunct UFO group in England claimed that one of their members had conducted experiments with dissimilar metals in the 1970's. He used two disks of the same dimension and thickness but of two different materials, copper and zinc. The disks were kept very close together and rotated in opposite directions. The claim was they levitated when spun, though the comment did not specify the requirement for high voltage as in the case of the Biefeld/Brown effect.

It was simply rotation of mass which is more consistent with Otis T. Carr, Bruce DePalma and Dr. Harold Aspden, with their claims of anomalous inertial or gravitic effects associated with rotating mass.

An interesting story was told at the recent Low Level Energy Conference by Michael Roberts, President of the Association for Push

Gravity Research. One day a few years ago, he got a phone call at his home in Waco. It was from a fellow who had stopped in Waco and wanted to meet Michael at a local mall.

Michael drove out to the mall and the man was parked, in his late model Jeep in a remote section of the parking lot. The man said he would like to show Michael what he had been working on.

The Jeep engine was off, the vehicle was put in neutral and was not braked in anyway. Michael was asked to push the vehicle. He did so with both hands, meeting an expected amount of resistance before he got it moving.

The man got in and braked the vehicle. He then showed Michael four mystery boxes (each about 12" x 6" x 4"), mounted in the top of each wheel well of the Jeep. Each box had an electrical cable that led under the hood. Michael was not allowed to see under the hood.

Immediately after the push test, the man got in the Jeep and flicked a toggle switch which had been installed under the dashboard. Michael was then asked to push the Jeep again, this time it moved with the light touch of one hand. The man would say nothing about how this miracle was accomplished, he just wanted to show Michael that it was possible to achieve an antigravity effect using electricity.

One possible explanation may be that the four boxes acted to provide a stabilized buoyancy type field, like pontoons on a boat. The use of only one would deflect the incoming gravity in one localized area, thus creating an imbalance. Whereas one unit over each wheel would equally distribute the deflection around the center of mass of the Jeep.

[AETHER SCIENCE AND ELECTRO-PROPULSION](#)

The little known 19th century Aether science lead up to Tesla's discovery of electro-propulsion. Tesla's plan was to build his electric flying machine, and to Dr.aw some of the environmental energy out of the cosmos.

This plan involved a theory of radioactivity under development by Tesla in the 1890s, which entirely presaged and conflicted with currently accepted Relativism, quantum mechanics, and nuclear energy theories. To Tesla, so-called atomic energy was in fact the result of environmental energy emanating from the cosmos, and made known to us via radioactive matter. This matter, Tesla said, had the peculiar property of resonating and reacting with ubiquitous cosmic radiation.

The cosmic radiation of which Tesla spoke was of much higher frequency than what we call radioactive emanations. Tesla believed that these were the result of a step-down process, in which certain peculiar matter reacts to and converts ubiquitous, omnidirectional cosmic radiation.

ZERO-POINT RADIATION

Today, we call this zero-point radiation (ZPR), from higher frequencies, to lower, more useful and appropriate frequencies, such as gamma, x-ray, ultraviolet, visible, infrared radiation, as well as magnetism and even electrical current. These step-down frequencies are much easier to detect and measure than the ZPR.

The existence of the ZPR was well known to Tesla in the 1890s, but it was not until recently that it became scientifically accepted as a proven fact. This radiation is of such high frequency that it normally passes through space, the earth, and our bodies without harm or incident, in constant equilibrium, because its short wavelengths do not normally react or resonate with the atoms of most matter.

It is radioactive matter, according to Tesla, which has a peculiar atomic structure which reacts with this radiation to produce radioactivity. Atomic energy, to Tesla, comes from the ZPR, not atoms. If a lump of radium could be shielded from the effects of the ZPR, said Tesla, it would show no radioactivity.

Most naturally radioactive elements are dense and unstable, that is, they are said by the Relativists to decay as radiation is emitted, to elements of lower atomic numbers.

The Relativists, with whom Tesla vehemently disagreed, believe that naturally radioactive elements spontaneously lose mass in the process of such decay, so that the energy released as radioactivity, is equivalent to the lost mass according to Einstein's equation, $E=mc^2$.

If non-radioactive elements are converted into radioactive elements by the forces of nature, what are these processes?

In a New York Times article of July 11, 1937 (pg.13, col.2), in one of Tesla's famous birthday announcements, Tesla stated that he had developed a process for the manufacture of radium (transmutation from other elements), which was so efficient that it could be sold for \$1.00 per pound.

He also announced that he had absolutely developed a system for the interstellar transmission of energy. He said he had been working in several laboratories, but refused to disclose their locations.

His working model, he said: "...employs more than three dozen of my inventions. It is a complex apparatus, an agglomeration of parts. It could convey several thousand units of horsepower to other planets, regardless of the distance. Traveling through a channel of less than one-half of one-millionth of a centimeter."

Further, he said: "This is not an experiment. I have built, demonstrated and used it. Only a little time will pass before I can give it to the world."

These facts demonstrate that even in his 80s, Tesla was involved in secret research at several undisclosed laboratories, on technology which even today remains highly classified. Technology that is only now being fully understood and secretly utilized.

SECRETS OF THE TESLA FLYING SAUCER

Bill Jones, writing for The UFO Enigma, the newsletter for the UFO Study Group of greater St. Louis, comments that Tesla did the basic research for constructing electromagnetic field lift-and-drive aircraft/spacecraft. From 1891 to 1893, he gave a set of lectures and demonstrations to groups of electrical engineers.

As part of each show, Tesla stood in the middle of the stage, using his 6' 6" height, with an assistant on either side, each seven feet away. All three men wore thick cork or rubber shoe soles to avoid being electrically grounded. Each assistant held a wire, part of a high voltage, low current circuit.

When Tesla raised his arms to each side, violet colored electricity jumped harmlessly across the gaps between the men. At high voltage and frequency in this arrangement, electricity flows over a surface, even the skin, rather than into it. This is a basic circuit which could be used by aircraft/spacecraft.

The hull is best made double, of thin, machinable, slightly flexible ceramic. This becomes a good electrical insulator, has no fire danger, resists any damaging effects of severe heat and cold, and has the hardness of armor, besides being easy for magnetic fields to pass through.

The inner hull is covered on its outside by wedge shaped thin metal sheets of copper or aluminum, bonded to the ceramic. Each sheet is three to four feet wide at the horizontal rim of the hull and tapers to a few inches wide at the top of the hull for the top set of metal sheets, or at the bottom for the bottom set of sheets. Each sheet is separated on either side from the next sheet by 1 or 2 inches of uncovered ceramic hull.

The top set of sheets and bottom set of sheets are separated by about 6 inches of uncovered ceramic hull around the horizontal rim of the hull. The outer hull protects these sheets from being short-circuited by wind-blown



Анализатор ВЛТ Трэн-Зоннер (система Уилуэя В. - (Сотус), уменьшена в радиусе 1/2) и включенный в программу сетки ионизации Redlight (Красный свет), сектор А (5d) радиуса 51 поворота ВРС Навис (ит. Нависа) - объект Дредланд ("Страна грех") в диаметре светового разбегательного излучения по преломлению АВВ (NSA) Galileo ("Галилей") - "Стороживая дорога" *

проточные турбины запитаны непосредственно от генератора (напряжения 30кВ) (напряжения 30кВ)

защитный экран из нержавеющей стали (смонтирован на основании)

продольный огонь и диаметр сектор на трансформаторе диаметра 115 (111) с люминесцентными лампами и защитой от искр в горючей среде и его световая мощность 4000 Вт

высвечиваются (очень яркими и тонкими линиями Al+Mg+... типа пробы) - при сильном облучении излучением

продольный огонь и диаметр сектор на трансформаторе диаметра 115 (111) с люминесцентными лампами и защитой от искр в горючей среде и его световая мощность 4000 Вт



горючая смесь (в основном излучение) излучается и усиливает радиацию от антенны

напряжение подается внутренним проводом Трансформатор и кабельная система каналов - кабелей питания

горючая смесь (в основном излучение) излучается и усиливает радиацию от антенны

- ★ Источники:
1. Опыты Фрица Роберта Кельера.
 2. Кельер, изобретение (по фотографии объекта гонимого типа, сделанной в Сандерленде в мае 1935г.).
 3. Алмаз (гранитный) оптический световод (Б. Андерсон, Ч. Моури и др.) той же ВЛТ.
 4. Демонстрация контактов.

metal foil (Air Force radar confusing chaff), heavy rain or concentrations of gasoline or kerosene fumes.

If unshielded, fuel fumes could be electrostatically attracted to the hull sheets, burn and form carbon deposits across the insulating gaps between the sheets, causing a short-circuit. The space, the outer hull with a slight negative charge, would absorb hits from micro-meteorites and cosmic rays (protons moving at near the speed of light).

Any danger of this type that doesn't already have a negative electric charge would get a negative charge in hitting the outer hull, and be repelled by the metal sheets before it could hit the inner hull. The hull can be made in a variety of shapes; sphere, football, disc, or streamlined rectangle or triangle, as long as these metal sheets,

"are of considerable area and arranged along ideal enveloping surfaces of very large radii of curvature,"

TESLA'S CONCEPT OF ELECTROGRAVITIC CRAFT ORIGINATED IN 1919:

"I am now planning aerial machines devoid of sustaining planes, ailerons, propellers and other external attachments, which will be capable of immense speeds."

The power plant for this machine can be a nuclear fission or fusion reactor for long range and long-term use to run a steam engine which turns the generators. A short-range machine can use a hydrogen oxygen fuel cell to run a low-voltage motor to turn the generators, occasionally recharging by hovering next to high voltage power lines and using antennas mounted on the outer hull to take in the electricity. The short-range machine can also have electricity beamed to it from a generating plant on a long-range aircraft/spacecraft or on the ground.

One standard for the generators is to have the same number of magnets as field coils. Tesla's preferred design was a thin disc holding 480 magnets

with 480 field coils wired in series surrounding it in close tolerance. At 50 revolutions per minute, it produces 19,400 cycles per second.

The electricity is fed into a number of large capacitors, one for each metal sheet. An automatic switch, adjustable in timing by the pilot, closes, and as the electricity jumps across the switch, back and forth, it raises its own frequency a switch being used for each capacitor.

The electricity goes into a Tesla transformer; again, one transformer for each capacitor. In an oil tank to insulate the windings and for cooling, and supported internally by wood, or plastic, pipe and fittings, each Tesla transformer looks like a short wider pipe that is moved along a longer, narrower pipe by an insulated non-electric cable handle. The short pipe, the primary, is six to ten windings (loops) of wire connected in series to the long pipe. The secondary is 460 to 600 windings, at the low voltage and frequency end.

The insulated non-electric cable handle is used through a set of automatic controls to move the primary coil to various places on the secondary coil. This is the frequency control.

The secondary coil has a low frequency and voltage end and a maximum voltage and frequency end. The greater the frequency the electricity, the more it pushes against the earth's electrostatic and electromagnetic fields.

The electricity comes out of the transformer at the high voltage end and goes by wire through the ceramic hull to the wide end of the metal sheet. The electricity jumps out on and flows over the metal sheet, giving off a very strong electromagnetic field, controlled by the transformer.

At the narrow end of the metal sheet, most of the high-voltage push having been given off, the electricity goes back by wire through the hull to a circuit breaker box (emergency shut off).

EXPLANATION FOR THE COLORED LIGHTS OF UFOs:

In bright sunlight, the aircraft/spacecraft may seem surrounded by hot air, this is a slight magnetic distortion of the light. In semi-darkness and night, the metal sheets glow, even through the thin ceramic outer hull, with different colors. The visible light is a by-product of the electricity flowing over the metal sheets, according to the frequencies used.

(Are we getting close to the explanation for the different colored lights that appear to surround the outer edges of a UFO? These have been described by UFO observers, including myself, over the years.)

Descending, landing or just starting to lift from the ground, the transformer primaries are near the secondary weak ends and therefore, the bottom set of sheets glow a misty red. Red may also appear at the front of the machine when it is moving forward fast, lessening resistance up front.

Orange appears for slow speed. Orange-yellow are for airplane-type speeds. Green and blue are for higher speeds. With a capacitor addition, making it oversized for the circuit, the blue becomes bright white, like a searchlight, with possible risk of damaging the metal sheets involved.

The highest visible frequency is violet, like Tesla's stage demonstrations, used for the highest speed along with the bright white. The colors are nearly coherent, of a single frequency, like a laser. A machine built with a set of super conducting magnets would simplify and reduce electricity needs from a vehicle's transformer circuits to the point of flying along efficiently and hovering with very little waste of electricity.

When Tesla was developing arc lights to run on alternating current, there was a bothersome high-pitched whine, whistle, or buzz, due to the electrodes rapidly heating and cooling. Tesla put this noise in the ultrasonic range with the special transformer already mentioned. The aircraft/spacecraft gives off such noises when working at low frequencies.

(I have personally noticed the distinctive whistle emanating from the F-22 Raptors flying out of Langley Air Base across the river from me and have wondered if it is related to what Tesla is describing. The common explanation I get is: "Raptors make this noise when the throttles are advanced. It's the influx of air into the intakes for the first few seconds of



throttle up that produces the noise." But an explanation from a F-22 pilot: "It's the anti-gravity drive! OOPS shouldn't have said that.")

Timing is important in the operation of this machine. For every three metal sheets, when the middle one is briefly turned off, the sheet on either side is energized, giving off the magnetic field. The next

instant, the middle sheet is energized, while the sheet on either side is briefly turned off.

There is a time delay in the capacitors recharging themselves, so at any time, half of all the metal sheets are energized and the other half are recharging, alternating all around the inner hull. This balances the machine, giving it very good stability. This balance is less when fewer of the circuits are in use.

At a fairly close range, the aircraft/spacecraft produces heating of persons and objects on the ground; but by hovering over an area at low altitude for maybe five or ten minutes, the machine also produces a column of very cold air down to the ground. As air molecules get into the strong magnetic fields that the machine is transmitting out, the air molecules become polarized and form lines, or strings, of air molecules.

The normal movement of the air is stopped, and there is suddenly a lot more room for air molecules in this area, so more air pours in. This expansion and the lack of normal air motion make the area intensely cold. This is also the reason that the aircraft/spacecraft can fly at supersonic speeds without making sonic booms.

As air flows over the hull, top and bottom, the air molecules form lines as they go through the magnetic fields of the metal sheet circuits. As the air molecules are left behind, they keep their line arrangements for a short time, long enough to cancel out the sonic boom shock waves.

Outside the earth's magnetic field, another propulsion system must be used, which relies on the first. You may have read of particle accelerators, or cyclotrons, or atom smashers. A particle accelerator is a circular loop of pipe that, in cross-section, is oval.

In a physics laboratory, most of the air in it is pumped out. The pipe loop is given a static electric charge, a small amount of hydrogen or other gas is given the same electric charge so the particles won't stick to the pipe. A set of electromagnets all around the pipe loop turn on and off, one after the other, pushing with one magnetic pole and pulling with the next, until those gas particles are racing around the pipe loop at nearly the speed of light.

Centrifugal force makes the particles speed closer to the outside edge of the pipe loop, still within the pipe. The particles break down into electrons, or light and other wavelengths, protons or cosmic rays, and neutrons if more than hydrogen is put in the accelerator.

At least two particle accelerators are used to balance each other and counter each other's tendency to make the craft spin. Otherwise, the machine would tend to want to start spinning, following the direction of the force being applied to the particles. The accelerators push in opposite directions.

The high-speed particles go out through straight lengths of pipe, charged like the loops and in speeding out into space, push the machine along. Doors control which pipes the particles leave from. This allows very long range acceleration and later deceleration at normal (earth) gravity. This avoids the severe problems of weightlessness, including lowered physical abilities of the crew. It is possible to use straight-line particle accelerators, even as few as one per machine, but these don't seem as able to get the best machine speed for the least amount of particles pushed out.

Using a constant acceleration of 32.2 feet per second provides earth normal gravity in deep space and only two gravities of stress in leaving the earth's gravity field. It takes, not counting air resistance, 18 minutes, 58 seconds to reach the 25,000 miles per hour speed to leave the earth's gravity field.

A shortwave radio can be used to find the exact frequencies that an aircraft/spacecraft is using, for each of the colors it may show, a color television can show the same overall color frequency that the nearby, but not extremely close, craft is using. This is limited in its use, as a machine traveling at the speed of a jet airliner may broadcast in a frequency range usually used for radar sets.

[EXPLANATION FOR WHY UFOs CAUSE CAR ENGINES TO STOP?](#)

The craft circuits would tend to override lower voltage electric circuits within and near their electromagnetic fields. One source briefly mentioned a 1941 incident, where a shortwave radio was used to override automobile ignition systems, up to three miles away.

How many UFO encounters have been reported in which automobile ignition systems have suddenly stopped?

TESLA'S CONNECTION TO THE PHILADELPHIA EXPERIMENT:

Nikola Tesla has recently been the subject of controversy due to the claims of Al Bielek and Preston Nichols. These men have reported in a number of books and articles that Tesla was involved in one of the most disputed mysteries of World War II, The Philadelphia Experiment.

The Philadelphia Experiment, otherwise known as Project Rainbow, was allegedly an attempt by the Navy to create a ship that could not be detected by magnetic mines and or radar. However, its results were said to be far different and much more dangerous than the Navy ever expected.

In the early 1930's, the University of Chicago investigated the possibility of invisibility through the use of electricity. This project was later moved to Princeton's Institute of Advanced Studies where it was named Project Rainbow (project invisibility), and was founded in 1936.

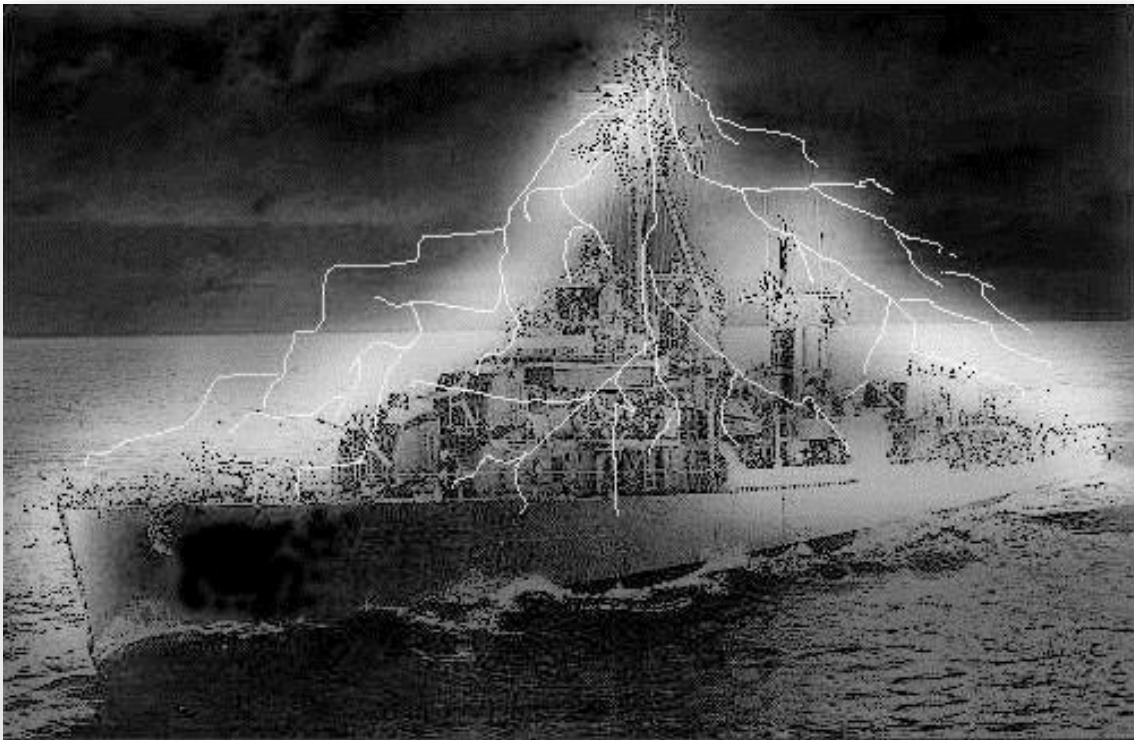

Nikola Tesla was named Director of the project. Tesla was given anything that was required by him for the testing of the project. Tesla required and was given a navy battle ship on which the experiments were to be tested. The first test of invisibility occurred in 1940 and was slated as a full success when a navy ship with no crew on board vanished from this plane of existence.

The basic design, had two large Tesla coils (electromagnets) placed on each hull of the ship. The coils are turned on in a special sequence and their magnetic force is so powerful that they warp gravity itself.

Based in part on Tesla's earlier electrogravitic experiments, Project Rainbow proved to be far more dangerous than was originally conceived.

Al Bielek claims that Tesla began to have doubts about the safety of the experiment due to his communications with extraterrestrials.

"Tesla had a press announcement in 1923 where he stated he was talking with ET's off planet. Now after he retired from RCA he maintained a laboratory in his living quarters at the Hotel New Yorker. Unknown to most people, he had a second laboratory which apparently was his main one on top of the Waldorf Astoria on the top floor and both penthouse towers.

"He maintained a transmitter setup on the Waldorf; and his receiving setup, his receiving antennas and receivers which had been built by RCA under his direction, were on the New Yorker. Two people who said they were working with Tesla, during that period, said that he was using that equipment to talk with somebody, virtually every day, and one of them was emphatic: it was someone off planet. Yes, he was communicating with ET's!"

Tesla stated that there would be a serious problem with personnel if anyone were to enter the ship while the gauss coils were turned on and the Electro Magnetic radiation would damage them within this reality. He said in numerous occasions that he was in contact with extraterrestrials

and that the ET's had confirmed that there would be a problem with the experiment.

Tesla wanted to clarify the problem before any farther experiments would begin. However, the Navy said no, they were fighting a war and wanted immediate results. On the second experiment, Tesla, fearing that there would be people hurt or killed in the experiment, decided to sabotage the 1942 test. He de-tuned the equipment so nothing would work and the test failed. Tesla resigned in March 1942 and left the project.

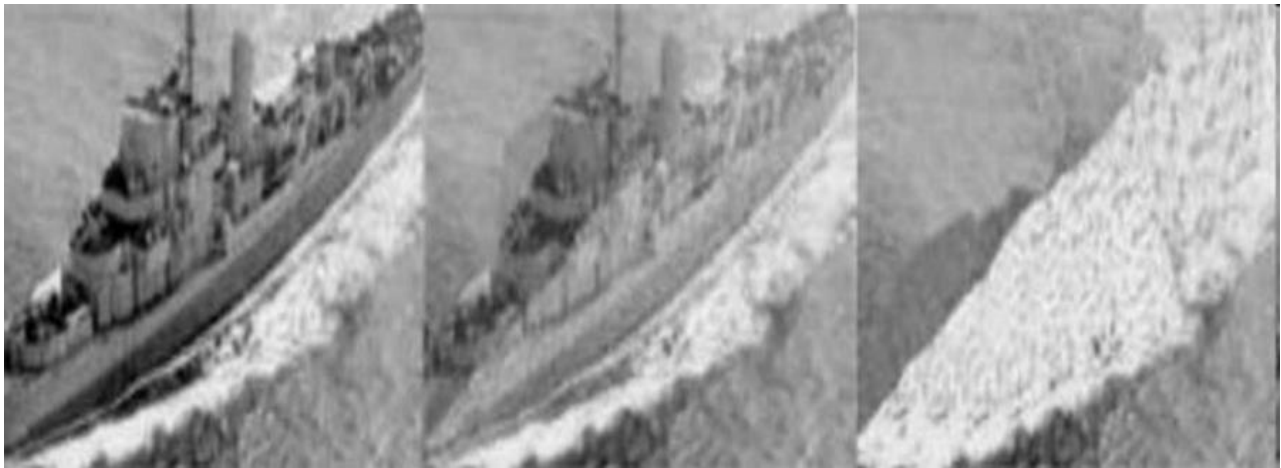

Senator Richard B. Russell Jr. Witness to UFO Sighting

Long kept secret, a declassified Air Force intelligence report has become one of the best pieces of evidence towards proving that UFOs really exist!

On October 13, 1955, U.S. Senator Richard B. Russell Jr, chairman of the Armed Services Committee at that time, was on a train traveling through the Transcaucasia Region located in the former Soviet Union. One of the most influential politicians of his time, Russell was accompanied by his aide, Col. E. U. Hathaway and his interpreter Ruben Efron. All of them witnessed an intriguing spectacle offered by two saucer-shaped craft as they flew in parallel with their train before zipping off into the distance.

After reaching the American Embassy in Prague, the three men gave official statements that were classified as TOP SECRET at that time. They were interviewed by a Lieutenant Colonel Thomas Ryan shortly after the sighting had taken place.



Richard B. Russell Jr.

SEN. RICHARD RUSSELL JR., WHOSE DECLASSIFIED TESTIMONY SHOWS HE SAW UFOS

According to the declassified reports, Russell was the first to see a flying disc “ascend and pass over the train.” Although Sen. Russell was somewhat familiar with the existence of secret projects and the spy planes being developed, he was still disturbed by what he had just witnessed and could not explain the origin of the highly-maneuverable and incredibly fast craft.

He then rushed to get Mr. Efron and Col. Hathaway to see it.

Col. Hathaway stated that he got to the window with the Senator in time to see the first UFO, while Mr. Efron said that he got only a short glimpse of the first. However, all three saw the second disc and all agreed that they saw the same round, disc-shaped craft as the first.

In the official report, Col. Ryan describes the incident as “an eyewitness account of the ascent and flight of an unconventional craft by three highly reliable United States observers.” The three men were not attention seekers but rather trustworthy representatives of the military and government, therefore their admissions were considered highly valuable depictions of the UFO phenomenon.

“I doubt if you’re going to believe this, but we all saw it. Senator Russell was the first to see this flying disc we’ve been told for years that there isn’t such a thing, but all of us saw it.”

Declassified CIA documents attest to the veracity of this incident, as the government agency recorded the interviews it held with the eyewitnesses. The documents show there was also a fourth witness whose name was withheld as he was a civilian traveling alone and wasn’t part of the Senator’s group.

This fourth witness described the UFOs as being identical, with “a slight dome and a white light on top.” The edge of both discs were glowing with a pinkish hue, not unlike the glowing plasma created during an electrical storm or St. Elmo’s fire. This aspect could attest to the craft being equipped with some kind of electromagnetic propulsion system that ionized the air around them.

The UFO rose “vertically with the glow moving slowly around the perimeter in a clockwise direction, giving the appearance of a pinwheel,” the description read.

In the CIA report, interpreter Ruben Efron told the agents that visibility was ideal during the sighting and, despite the train moving, he had had a

Caucasus/Transcaucasia		IR 193-55		CLASSIFICATION	
AIR INTELLIGENCE INFORMATION REPORT					
COUNTRY OR AREA REPORT CONCERNS USSR			DATE OF INFORMATION 4 OCT. 55		SRI STATUS (If applicable) SRI NO. TIC 6244
ACTIVITY SUBMITTING REPORT US AIR ATTACHE			DATE OF COLLECTION 13 OCT. 55		
PREPARING INDIVIDUAL LT. COL. THOMAS S. RYAN			DATE OF REPORT 14 OCT. 55		SRI NO. CANCEL
NAME OR DESCRIPTION OF SOURCE LT. COL. E.U. HATHAWAY			EVALUATION B-2		SRI NO. ADDITIONAL INFORMATION
REFERENCES (DATE Subject, previous reports, etc., as applicable) BAIR 3A; 2T2; 3A3; 13A13; 3A15. USAIRA CABLE (TS) C-103 dtd 13 OCT 55					
SUBJECT (Descriptive title. Use individual reports for separate subjects) OBSERVATIONS OF TRAVELLER IN USSR					
SUMMARY (Give summary which highlights the salient factors of narrative report. Begin narrative text on a new line unless report can be fully stated on AF Form 117. List Inclusions, including number of copies)					
<p>This report contains an eye witness account of the ascent flight of an unconventional aircraft in the Trans Caucasus region of USSR. This aircraft was reported by three highly reliable United States observers who were travelling by rail at the time of the sighting. The three observers were firmly convinced that they saw a <u>genuine flying saucer or flying disc</u>. Two sightings occurred at 1910 hours on 4 Oct between ATJATY and ADZHLJABUL, ten minutes by rail after departing A. One disc aircraft ascended almost vertically, at a relatively slow speed its outer surface revolving slowly to the right, to an altitude of 2000 feet where its speed then increased sharply as it headed north. The flying disc was seen performing the same actions about one minute later. The take-off area was about 1-2 miles south of the rail line where two small bushes were seen pointing up almost vertically. All o</p>					

clear field of view. He was able to see that as it approached the train, the first UFO "gave the appearance of gliding."

"No noise was heard, no exhaust was heard, and no exhaust glow or trail was seen by me."

Documents show that in the moments following the incident, Sen. Russel took the matter very seriously with his aide and interpreter.

"We saw a flying disc. I wanted you boys to see it so that I would have witnesses."

A declassified FBI memo, dated one month after the events in Transcaucasia admits that Sen. Russel and Col Hathaway's testimonies "would support the existence of a flying saucer"

Alec Newald Reveals Interesting Info from Aliens

As an alien reportedly told Alec Newald in his book "Coevolution," an extra dimension can be defined as:

"an oscillatory realm that is out of phase with your own (that is, in another dimension)."

Aliens report that brains can both manipulate and be sensitive to negative energy and electrogravity, so alien telepathy involves a subtle shift into extra dimensions of mind.

One Monday in mid-February 1989, Alec Newald set off on what should have been a three-hour drive from Rotorua to Auckland, in New Zealand. He arrived in Auckland feeling tired and confused, but was even more confused to learn that Monday was now Thursday ten days later, and that he had no idea of what had happened in the meantime!

When Alec did retrieve his memories of those missing ten days, he realized his life had changed forever. Early on in that fateful trip, while driving through a foggy mountain pass, Alec was whisked from the road by beings from an extraterrestrial civilization.

What he learned and experienced during his stay with these friendly beings has profound implications for all of us here on earth.

Soon after his "return", Alec received strange visits from "government scientists" wanting to know about his experience.

Among other things, they were keen to learn what he had noticed about the capabilities of this alien race. Alec was uncooperative and soon found himself in "hot water".

It was obvious that these "scientists" knew all about Alec's abductors' and expected they would return to Earth one day - soon.

Through Alec's experiences he has written a book called "Co-Evolution". Which is what the following information will be drawn from. I will be focusing on some of the events that transpired, during his Abduction and a little of what happened on his return.

I felt it was important to share with you some of the interesting things in his 1999 book which is now out of print and very hard to find.

THE HIDDEN REALITY

There is much about this planet's history that has never been told. I do not speak here of yet to be discovered historical facts, but only of material that is already known by a select few within our communities.

Most of this knowledge has been carried through the ages and jealously guarded by the few secret sects that were privy to it from its inception, but these sects were not necessarily "secret" at the time this information was first placed in their trust. The original intention was that this ancient knowledge would be shared with this planet's inheritors, en masse, when the trust holders deemed it appropriate.

The species slated for inheritance of this knowledge is known as Homo Sapiens. For your information, Homo Sapiens and the Cro-Magnon precursor species were artificially engineered!

The final pieces of the Cro-Magnon jigsaw puzzle were put together approximately 70,000 years ago. This was not the first humanoid creature to walk planet Earth, but it was the first type ever to be constructed to act as a receiver or container so that a second "bodiless" entity could cohabit with this humanoid form to experience physicality through the

actions of its host's solid outer body form! You may recognize this entity if I refer to it as the soul or spirit.

This new species was designed to be able to take on board all the stored information that awaited it at any time in the future. In other words, it was already fully developed in its mental capabilities and required no further improvements or evolutionary developments at that point. All the knowledge that would ever be needed by this race, up until it's next evolutionary step, was already present on the planet and in the safekeeping of the trustees.

These trust holders have long since broken their vows to the givers of the knowledge, and I think that until very recently they had even forgotten the identity of their ancient benefactors. Perhaps a day of reckoning is close at hand for the trustees.

It may now be a little clearer to you as to why the secret sects or governors of our planet would prefer that the anticipated visit from the "Landlord" did not take place!

Following are some of Alec's drawings that he made upon his return. Alec's experience is one of the most documented and intriguing cases in UFO Abductions that I've come across. The knowledge he gained from the experience is priceless.

Below are actual quotes from Alec's book "Co-Evolution"

"MEETING THE GUARDIAN"

Looking up, I realized we were being approached by three aliens, the tallest of them looking like my female escort from earlier on. The second one was just a little shorter and was male as far as I could tell. The third was smaller, much smaller, and walked ahead of the other two.

He, for want of a better word was slightly built with a roundish head and rather unusual, squinty eyes which were well spaced and placed rather lower down than are our own. He had a very small mouth, but I did not notice any ears or much of a nose. His physical appearance, however,

was of almost no consequence, for I was immediately struck with an almost overpowering feeling of his presence. I cannot say it was hypnotic; if anything, the opposite. It was as if his energy was being projected and absorbed by my body.

There is no way I could ever adequately describe this sensation to you, using mere words. Those who have had this experience will know just what I mean! His communication with me was also much stronger and clearer than I had experienced with any of the others.

This was still not the "alien" I had read about or seen graphically illustrated in various magazines or papers.

The size was about right - four feet in height with a slight frame.

"Welcome", he said. "I am the designated Guardian of this section. Anything that you feel you might need to make your stay with us more pleasant, ask and I shall do my best to supply it. The suit you have been given will make it possible for you to understand us, and us you".

He must have read my mind as he entered the room, for I had just asked about the suits.

"We do not speak as such, as you will have noticed by now. Sometimes a verbal sound message is necessary in long distance."

"I will not enquire if you wish to stay or return at this time. I would hope you may desire the chance to absorb more knowledge and understanding before you make that decision. There are things we cannot tell you at this point in time.

You will understand I hope. Nevertheless, you will have the chance to acquire some considerable knowledge on a wide variety of subjects, including your own kind, before you make up your mind up on this.

However, some or all of this knowledge may have to be removed from you, should you decide to leave us and return to your own planet."

"THE ARRIVAL"

The first most striking thing about the city was its neatness and order; the second, it's immensity. Even from well up I could not make out the boundaries.

There may well be bigger cities on Earth, but where I come from this place would be rated big, VERY big. It stretched out in both directions, following the coastline out of my line of sight. There seemed to be only a thin strip of land that was not coastline or desert, and the city was sandwiched within it.

As we dropped in altitude, the sea lost its bluish look and turned almost black. There could not have been much wind as it looked very glasslike. I

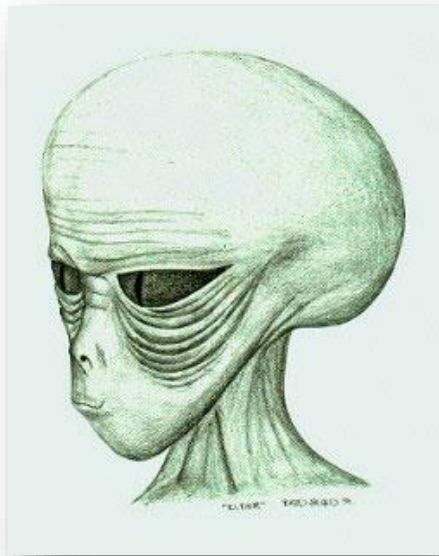

could make out a dark outline not too far off the coast which presumably was a deep drop off from the coastal shallows.

The last thing really to make an impact upon me was the lack of tall buildings, save for the odd tower or two, and the dominance of a small circular shapes among a few larger pyramid shaped constructions.

Hardly more than a minute had passed since we had entered the atmosphere, but now the craft had already settled. There was a mixture of apprehension and excitement within me. Now that I was here - wherever "here" was, just what had happened to me really started to sink in. Would I ever see home again? Was anyone looking for me?

My panic soon eased, however and curiosity won the day. I eagerly scanned the viewer for my first close look at the alien landscape. What I

could see was an area of level ground, similar to a courtyard, leading to two pyramid shaped buildings.

They appeared to be made from a material that looked just like tinted glass or semi-transparent plastic. I couldn't quite see the apex of these buildings from my vantage point, but later I was to find that they were capped with a spiral tower or antenna arrangement. The height of the tower added approximately twenty five percent to the buildings overall height. Each building in turn was topped with what I can only describe as a large light bulb. As peculiar as it may sound, I was sure I had seen something like this before, in the distant past.

These bulbs glowed day and night, and upon closer inspection appeared to be of a net or mesh construction rather than being glass spheres.

There appeared to be some form of electromagnetic grid or shielding device above the actual landing site, possibly a force field or energy gathering device.

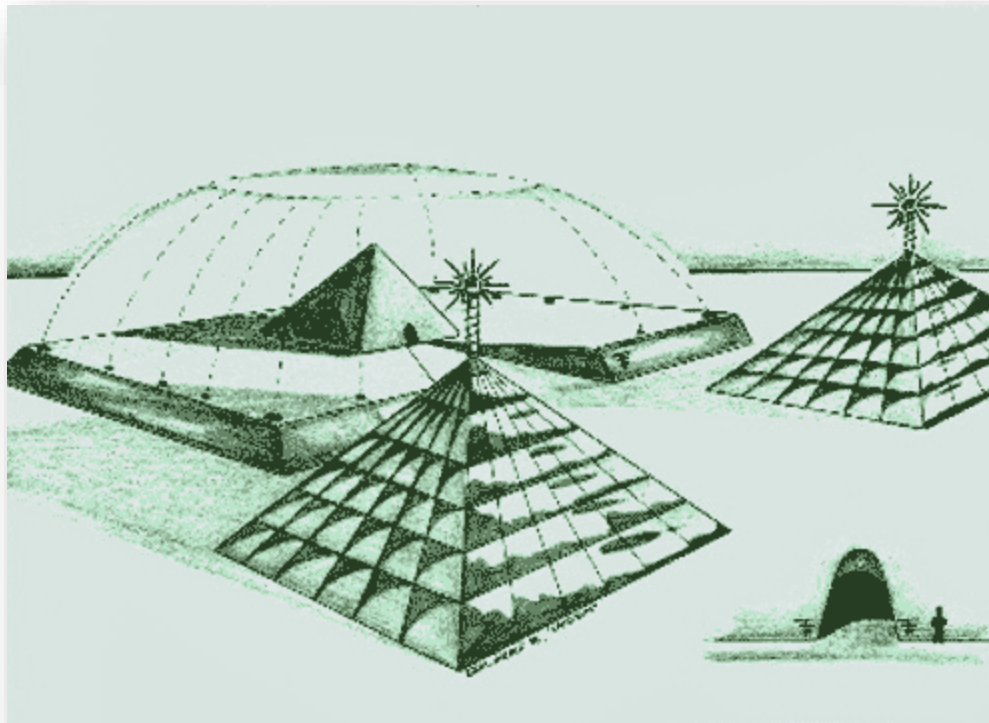

There was a short walk to one of the large structures which I had seen from inside the craft.

The air was still and amazingly quiet. Indeed, it was not until I had stepped out of the transporter that I realized there must have been some sort of background noise on board although I'd not noticed it at the time.

The surface upon which I was walking was not unlike cork, it appeared to be porous and slightly yielding underfoot.

"Spiral Tower Building
Possible Energy Transmitter
or Receiver"

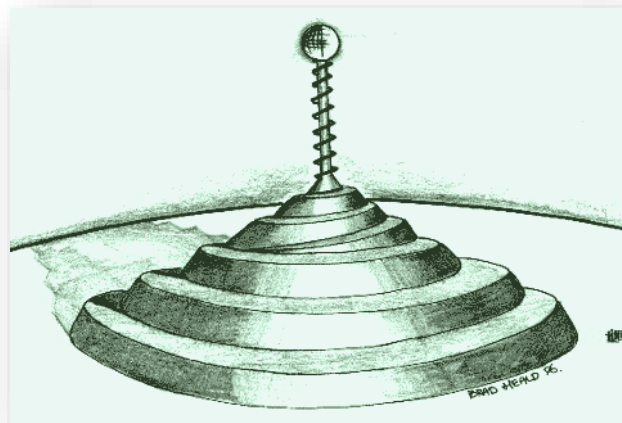

"THE DWELLINGS"

I was at a loss as to which way to look for a while,

such was my curiosity and awe at what was around me. Some buildings resembled those on Earth, but the outer walls were sloped back at approximately thirty-degree angles and set back some distance at each floor level, making them look more like steps up a hill.

Most of the buildings were circular or tube like in shape. They were laid out in a spiral pattern with the tallest buildings in the center, but the heights became progressively lower as the buildings spiraled out. All the buildings appeared to be made of glass or plastic.

Access to the upper levels of the home I was staying in, was by way of a gentle sloping spiral ramp which skirted the curved perimeters of the walls. This ramp could also be seen from the outside of the building. My personal observation of this feature is that it could have been a form or frame or reinforcement for the dwelling.

The rooms or, rather, the various levels were lit by some form of diffused lighting, both day and night, but I could find no direct source to explain this light. As we reached the second level, their main living area, I was stunned by the beauty and layout. No matter how hard I try here, my description cannot do it justice.

The color was predominantly pearl white with perhaps a touch of silver grey within. This may have helped remove any glare, for I can assure you there was none. Reflected from even deeper within were all the colors of the rainbow, not unlike a mother of pearl seashell. The soft light I mentioned earlier appeared to radiate from everywhere. To say it was a truly amazing sight is grossly inadequate!

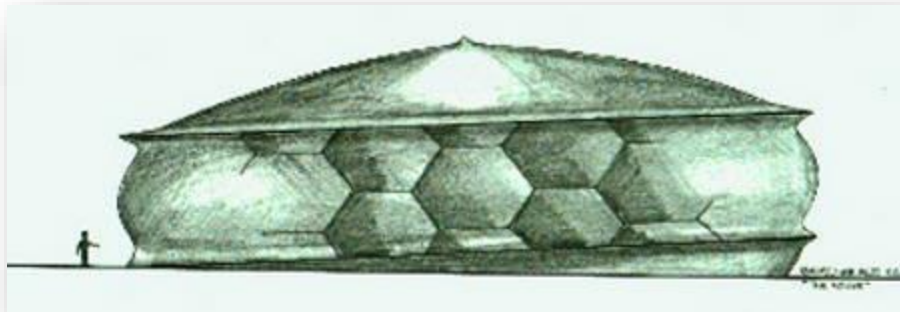

"Variant of Dwelling or House, also Three Stories high - Hexagonal Crystalline Pattern Within Walls"

I'm not even sure if it was the color that was the most stunning aspect of the interior, for I was equally smitten with the molded flow of form from one section, shape or partition into the next.

It was as if the whole dwelling, including every item of furniture, had been constructed simultaneously. Again, there appeared to be no joints or seams that I could distinguish. However, this dwelling had been constructed, similar techniques to those used in the transporter must have been employed. The floor, a smooth, padded rubber, was soft to walk on; the color, just one or two shades darker than the walls.

The furniture looked to be made from the now quite familiar glass or plastic substance. Although it was slightly tinted or smoky, all the colors of the rainbow seemed to be deep within it.

These colors could be changed by a person's thought patterns, so if you were excited there was no way to keep it a secret as the room's colors would dance about right through the color spectrum. When a person was in meditation, the light level would drop and only the softer tones would come through.

The central space of this room upon the second level was circular and used as a general-purpose area, including for meditation. Bedrooms as such had been made totally redundant, with meditation having entirely taken the place of sleep.

These meditative states would last for an hour or two each day.

"THE TRANSPORT"

Like most other items that were not made from natural products or grown, the car appeared to be made from a plastic like material. Even here, there is room but doubt in my mind as to whether this plastic was indeed a synthetic product of some natural substance, the like of which we do not have on earth. The reason for this doubt shall soon become apparent to you.

The top half was transparent but heavily tinted, the bottom, opaque and greyish brown. I guess you could say it was even vaguely pyramidal in shape, but it had a squashed and stretched out look compared to a conventional pyramid. There were no wheels, and it sat a few inches above the ground, even though it was not yet in motion.

If you could imagine a stealth fighter cockpit without wings, you would not be far off the mark.

"How does this thing work? I asked.

"Part mind power, part magnetic repulsion" I was told.

I decided perhaps I wouldn't ask too much more about its internal parts.

"Well, how can I drive it then?" was going to be my next question, but before I could even ask she responded.

"You guide, I'll provide the power", she said, sliding back the top section.

"Like this". She was reaching over and moving a slider from side to side.

"That is the manual way of doing it. I don't think you're quite up to doing that by pure thought yet Alec".

"I doubt it", I was thinking to myself without sending the thought to her. Yes, I had at least learnt to keep some thoughts to myself!

"Looks easy enough", I said confidently as I got into the car.

"Just set the slider.... that's right. Straight ahead is in the middle, sliding it to the right side will turn us right at the next available intersection. Don't worry", she emphasized, "it won't turn until the road guides let it. Then it will reset to the middle, awaiting the next instruction. I'll navigate", she said.

I was hesitant. "Come on let's go" she added impatiently, "and do not forget your extra eye protection".

These glasses or goggles were an event in themselves. The only way to describe how they were attached is to say they simply stuck to your face of suit-covering material without any other support. There was some sort of interaction of materials, as far as I could tell.

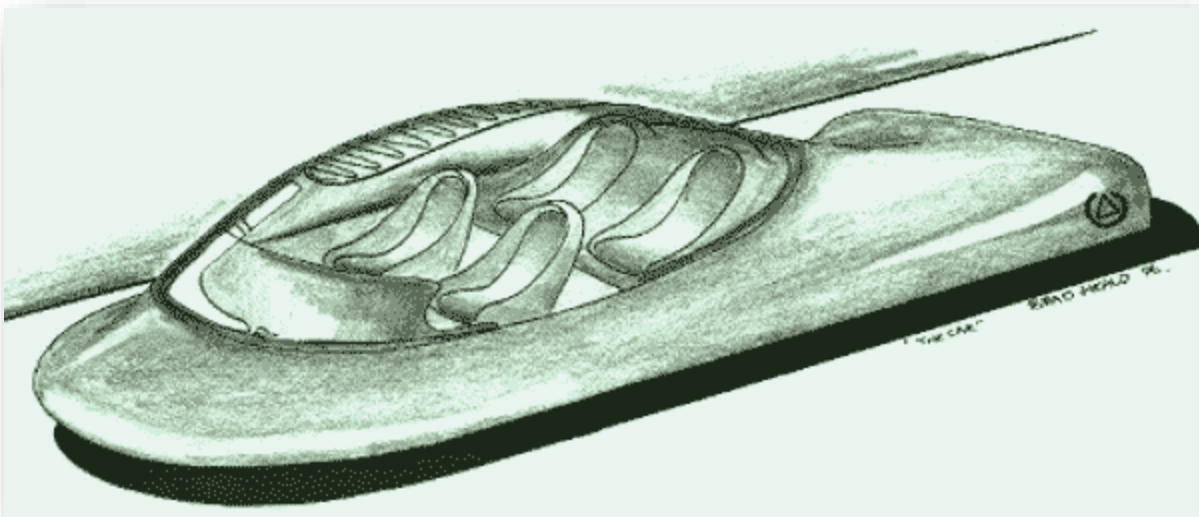

The car's guidance system had me puzzled. As the vehicle did not actually touch the ground, how did it know when to turn? It was suspended above the road by a form of magnetic repulsion, the details of which I did not get into but which didn't seem all that complex.

I'm sure it could be reproduced here on Earth without too much trouble. In some way, the vehicle would have to set up an electromagnetic field, or charge some particles and not others, in order to find its way around corners and so on without being instructed to do so.

"SPECULATIONS ON FUTURE TECHNOLOGY"

My objectives in writing this book was to give a factual report on an actual incident. While I have tried to keep any speculation on my part to a minimum, if I have included any it was not my intention.

Wherever possible, I have tried to remain neutral, at least as far as the off-planet segments are concerned. However, my demise at the hands of terrestrial authorities has made it difficult for me to remain neutral in that area. Perhaps you will forgive me this transgression.

What I'd like to do here is unleash upon you some personal speculation (albeit based on fact), as to how some of what you've just read might be more easily understood in the world of terrestrial reality.

The year 1947 (coincidentally, the same year as the now infamous Roswell saucer retrieval incident) heralded one of the biggest single technological breakthroughs of this century when, on the 23rd of December at the Bell Laboratories, inventors John Bardeen, Walter Brattain and William Shockley unveiled the first point-contact transistors.

Shockley followed up a year or so later with his junction transistor development. This amazing new technology amplified electrical signals by passing them through a solid semiconductor material - basically the same operation performed by present day junction transistors.

What resulted from this invention has been little short of miraculous, even "out of this world", dare I say. Following on from here, we end up deep within the next subject.

Most substances can exist in three different states, solid liquid and gaseous. Temperatures and pressures determine which state is adopted. The solid state is usually crystalline.

Differences between the three fundamental states are often depicted by simple diagrams in which atoms are represented by circles. Usually these circles are clustered together in a roughly spherical layout, at least with the solid and liquid states. However, when the atoms are replaced by molecules that are elongated in one direction, a peculiar intermediate state of matter arises: the liquid crystal.

We must therefore conclude that there are more than just three states of matter.

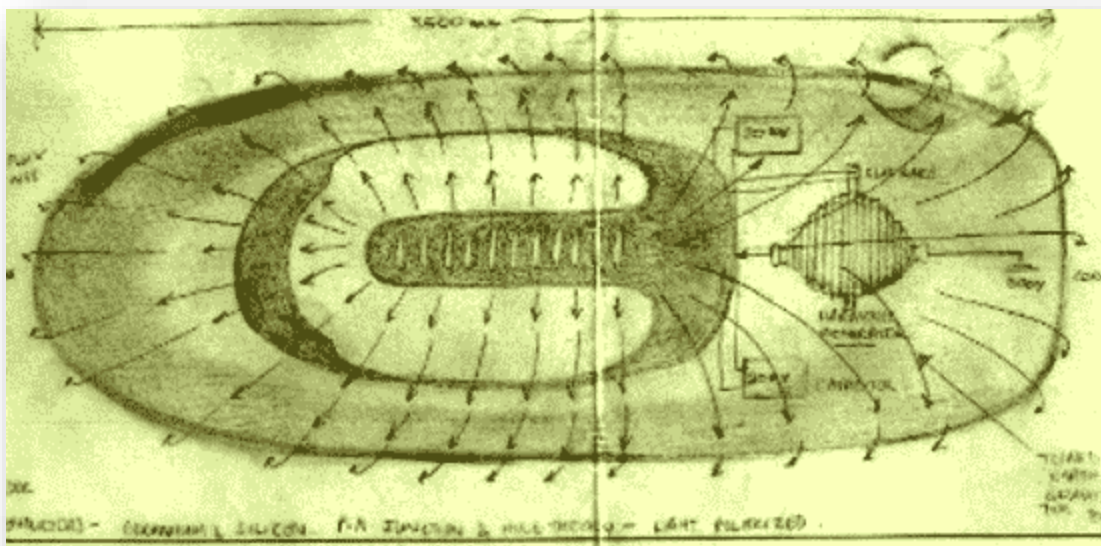

"Another Viewpoint of The Transport That Alec Used"

Another related subject concerns a group of organic superconductors known as Bechgaard salts, discovered in 1985. I mention them here because they have interesting characteristics in relation to UFO sightings.

If light is shone at the crystal but is polarized parallel to the conducting direction, it is reflected, this giving the crystal a characteristic metallic luster. Polarization in the transverse direction produces a dull grey appearance. If the power supply is turned off, the material disappears from sight. How about that! Conclusion: just because something looks like it's made of metallic substance, this does not necessarily mean that it is!

Since 1989, I have had two thirds of a jigsaw puzzle in my head. I knew that my aliens' craft could have changed shape on command and that these craft were in fact living entities in their own right.

I knew that some form of crystalline technology, possibly using a pulsed resonance or vibrational frequency along with temperature variations, was being used to go interdimensional. What I did not know or understand was how all this could be put together, but since the white powder gold article appeared in "Nexus Magazine". I may possibly have found the missing link!

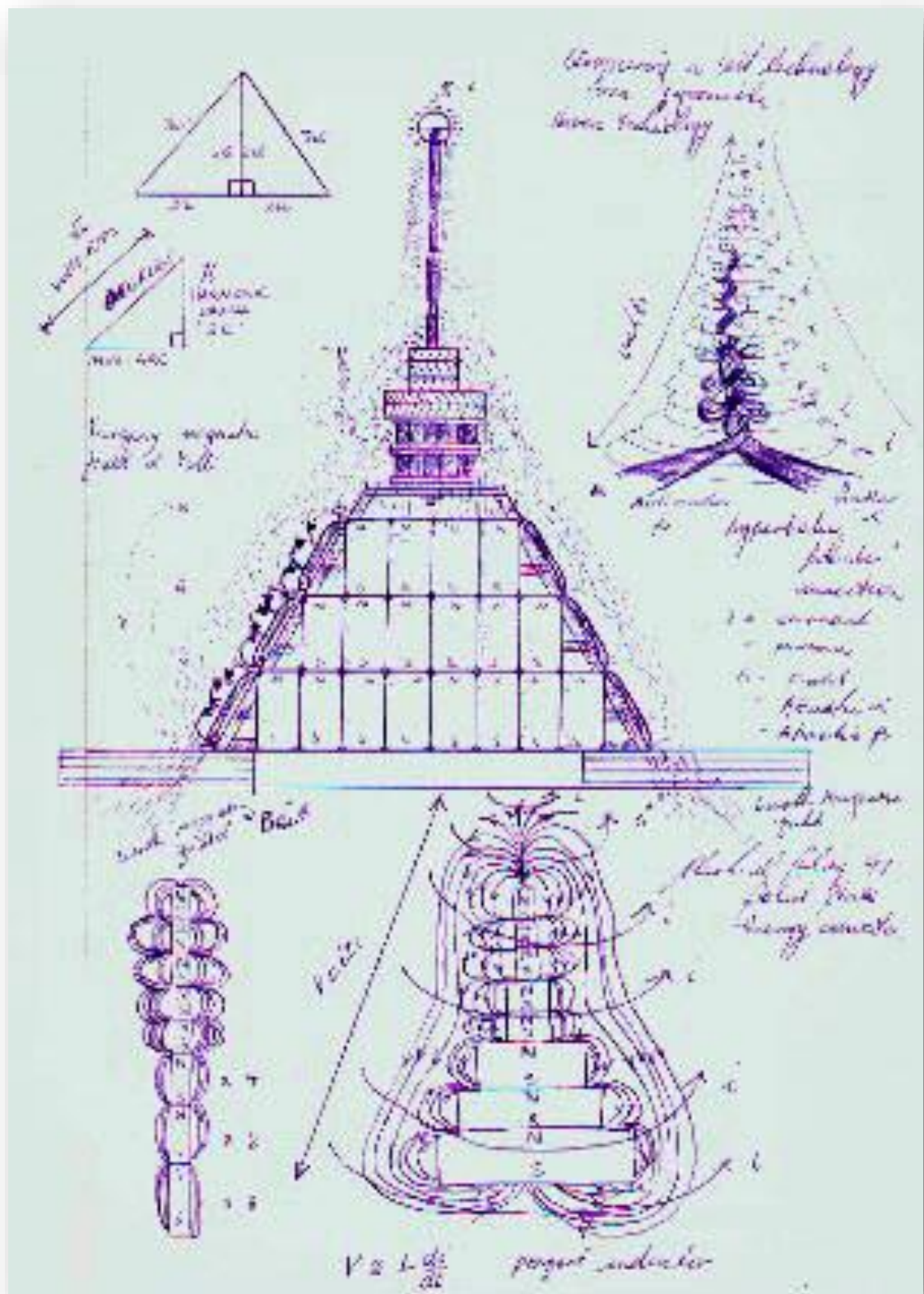

"This is a drawing Made by Alec Upon His Return to Earth, it was of a Generator that he saw, and this is his depiction of it"

"CLOSURE"

Upon Alec's return to this Planet, it was obvious from the start that some governmental agency knew about his "off world" experience, and wanted to get as much information out of him as humanly possible.

Two New Zealand DSIR scientists visited him wanting to know rather a lot of information about things they should never of even known about.... It soon became apparent that these two "gentlemen" were not DSIR (Department of Scientific & Industrial Research) at all.

The harassment continued and intensified, with his flat being broken into several times, even though Alec continually changed addresses to try and shake these people off his trail. Their demeanor was always threatening and when Alec refused point blank to cooperate with these individuals, they really started to play "hard ball!"

As I stated at the beginning of this review of Alec's experience, there it is not possible to do this story justice in just a couple of pages. The entire experience is one that will utterly amaze you. From start to finish it one of the best documented and illustrated abduction experiences that I have ever read.

During Alec's experience, he had access to ancient records of earth's history, which in itself spins a story that will put a lot more of the pieces of the jigsaw puzzle together on how this planet evolved.

"I do not know what I may appear to the world, but to myself I seem to have been only a boy playing on the seashore and diverting myself in now and then, finding a smoother pebble or a prettier shell than ordinary, whilst the great ocean of truth lay all undiscovered before me."

Researcher David Jacobs Comments on Aliens

Jacobs is considered the world's foremost academic scholar on the UFO and abduction phenomenon, and he teaches the only regular curriculum course on the subject in the United States

“During visualization procedures, such aliens might show an abductee a multitude of images: atomic explosions, meteorites striking the Earth, the world cracking in half, environmental degradation, ecological disaster, dead people bathed in blood strewn about the landscape, and survivors begging for help.

Or the aliens might show abductees images of Jesus, Mary or other religious figures. These images have the effect of being so vivid that



abductees think the events ‘really happened’ or they ‘really saw’ the religious figure.”

Such experiences arouse great fear, if not passive obedience to the abductors’ agenda.

Other messages seek to limit reports to other humans in order to buy the given aliens more time to work the larger human-alien interaction in their favor.

Generally speaking, reports about first contact with aliens are vivid and breathtaking. Interaction with aliens tends to revolutionize a person's thinking. Fantastic, otherworldly possibilities come to mind, along with the awareness that humans aren't alone.

In order to understand how aliens think about other aliens, we need to bump up the human model of physics and move it beyond old, pre-quantum notions of locally defined "things" of a concrete sort. In part, this

requires a suspension of some posited (but not proven) assumptions like Einstein's speed of light limit on propagation.

Aliens have stated and have demonstrated that their equations don't agree with the Einstein limit.

One explicit example is the pre-noted alien's suggestion that we should think in terms of thresholds that slightly \pm (plus or minus) exceed the speed of light, i.e. negative energy fluctuations that are part of a "negative cycle" described by aliens and touched on in Ford and Roman's Jan. 2000 Scientific American article on negative energy.

Humans still propagate the gospel of self-interest (separate, whole-numbered identity), a Darwinian detachment that superficially mirrors "the logic" of the animal world.

Aliens often ask how humans can do so without realizing that it risks the survival of our only planet. Through greater experience, aliens appear to have learned that a failure to plan and control population and resource use can be oppressive, if not fatal to a planet. Who has ever read or heard about alien poor - in the human sense, aliens who lack medical care and access to a good education (functionally, although not necessarily politically)?

Of course, some aliens are poor in resources, especially biological resources, because some planets are reportedly ruined by reckless regimes, depletion, and interventions like those of the grey alignment.

Please remember that aliens come from a variety of planets, some of which are second or latter generation - the place where aliens moved after their old world or star became too dangerous. Some aliens reportedly moved to "terra-formed" extra planets in order to accommodate their expanded numbers.

Others now live on small, dry planets of brief habitability near dangerously unstable stars. In some cases, aliens reportedly use magnetogravity to create a magnetic field and contain an atmosphere on what would

otherwise be a lifeless planet. Preliminary alien reports to humans who write on the subject indicate that we're lucky to live on a biologically mature planet with lush plant and (currently diminishing) animal life.

Again, aliens ask why we don't organize global conventions to protect the remaining species that live here and preserve our planet for "the longest possible" term, to quote one advanced alien.

If we fail to do so, we'll disappoint aliens who would like to visit and study our ecosystem. Worse yet, there's a fear among aliens that if we do too much damage to Earth, humans may become a traveling basket case, a homeless population that encroaches on other aliens' future plans. Along with other humans, I hear such statements at intervals.

Dr. Richard Bonenfant
Whitehall, NY Bigfoot Sightings, UFO Activity

Richard Bonenfant, Ph.D., is a retired research scientist and lecturer. His research career at Albany Medical Center Hospital and the New York State Department of Health was centered on the study of birth defects in newborn children. With advanced degrees in Anthropology and Psychology, Dr. Bonenfant served as an adjunct professor at Siena College in Loudonville, NY and City College in Gainesville, FL.

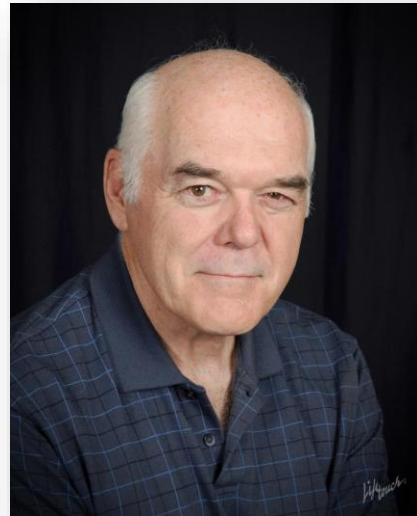

FROM HIS 1976 PRIVATE NOTES:

At the time, I was interested in a flurry of UFO activity taking place in upstate New York and on my free time would investigate some of the UFO sightings that came to my attention in my immediate vicinity.



On August 25, 1976 I received a telephone call from Ray Fowler, a well-known UFO investigator and author living near Boston. Ray informed me that the FAA had received reports of UFO activity near Whitehall, NY some two hours or so north of where I lived in Delmar.

He asked if I would follow-up on these sighting reports. When I agreed to do so, he directed me to initiate the investigation by contacting a NY State trooper in Whitehall by the name of Donovan.

I contacted Trooper Donovan as requested. He verified the sighting of large object accompanied by two smaller red ones at Scott Lake near Whitehall by some 15 witnesses. In passing he then added that strange reports were also coming in of a "big hairy animal" around Whitehall. For further information, I was referred to a Whitehall police patrolman by the name of Brian Gosselin.

Unfortunately, I was unable to reach Patrolman Gosselin that day but left my name and telephone number for further contact. On the following day, I received a call from a Whitehall Police Department desk sergeant who told me (off-the-record) that they had in fact received several reports from reliable witnesses of a large, 8-foot-tall, hairy ape creature in the countryside surrounding Whitehall. He further informed me that photos and even a plaster cast of the creature's footprints had been made. I was further told to see witness Darin Lamphere about the affair and referred to the Washington County Sheriff's Department. When I asked if I could examine their log book for further additional references to the unusual creature, the sergeant told me that I would need clearance from Chief Williams to order do so. Unfortunately, I was never able to reach the man.



That same day, August 26, 1976, I spoke to Deputy Walter Kruger of the Washington County Sheriff's Department. Deputy Kruger was only able to tell me about the UFOs sighting they had received and who to contact about these sighting but nothing was forthcoming about the hairy creature sightings in Whitehall.

On Friday, August 27, 1976, I received two collect calls from Officer Brian Gosselin. The officer confirmed the local UFO sightings but then also volunteered that he himself had encountered the strange hairy animal

everyone was talking about from a distance of only 20 feet. The creature was described as being unusually tall, stood on two legs, and must have weighed about 350 pounds. Furthermore, it had large red eyes, long arms and was covered with dark brown hair.

Officer Gosselin said he came upon the creature one night while on patrol. He first detected the creature when illuminated by his headlights as it crossed the road ahead of his patrol car. When he came upon it, the creature "screamed like a woman," flung its arm over its eyes, and ran into a nearby field. When he turned his spotlight in the area where it had departed, he saw large, reflective, nocturnal eyes off in the distance. The officer also mentioned that the creature moved as if heavy weights were attached to arms and legs. A state police patrol car happens to arrive at the scene moments later and the troopers within also spotted the creature before it departed into the deeper woods.

When questioned about a possible association of the creature with UFO sightings in the area, Officer Gosselin reported that he felt the sightings were independent of one another and went on to say that there have been several historical reports of such a creature around the area; sightings that many silent witnesses refuse to make known.

On Saturday, September 4, 1976 I went to Whitehall accompanied by my father-in-law to investigate UFO sighting in the region. While there visited Officer Gosselin at home where he filled sighting questionnaire both about UFOs and his bigfoot sighting. It was then that I learned the he had observed the bigfoot creature from his patrol car on two occasions on the night of Wednesday, August 24th. It was observed at almost the same location of a similar sighting the previous evening by another witness named Marty Paddock.

During the interview, I learned that the creature's hair appeared to be longer about the head. Officer Gosselin also added that the creature's movements were "slow and deliberate." He then led us to the sites where he had encountered the hairy creature.

The second site was about a mile further away than the first one. While there I was told by Officer Gosselin that a local man in the area had even taken a shot at the creature. This time the Officer admitted that UFOs sightings had occurred in the same general location as these bigfoot sightings. Lastly, Officer Gosselin reported being annoyed by all kinds of curious people about his bigfoot sighting. Before leaving I took a number of 35 mm color slides of both Officer Gosselin and the sites where his bigfoot sightings had occurred.

Later that month, on Sunday, September 25, 1976, I (Richard Bonenfant) accompanied by two companions (Benton Jamison, a professor in the Department of Mathematics at the State University of New York at Albany and Sharon Ellis - a medical illustrator for Albany Medical College) went to Whitehall to interview Officer Gosselin and two brothers who also observed the bigfoot. Our purpose in doing so was to attempt to gain additional descriptive information and allow Sharon Elis to sketch the creature they had all witnessed. Her profile and frontal view sketches were continually corrected until all witnesses agreed on its accuracy. Later she used ink to finalize her sketch.

In summary, the witnesses agreed that the bigfoot they came upon stood 7 and 1/2 feet to 8 feet tall, was covered by a shaggy dark brown coat, had long arms that swung like a pendulum when it walked, possessed large red bulging eyes and weighed about 350 pounds.

Officer Gosselin observed the creature for about two minutes that night from as close as 20-25 feet. While unsure, they believed the creature had fingers and that it was slightly hunchbacked. That sighting took place on August 25, 1976 at 11:10 in the evening.

The immediate duration of that sighting was about 20 seconds although he could still see and smell the creature for an additional 2 minutes. At one point the officer drew his sidearm and considered shooting the creature in order to acquire proof of what he had just seen. He didn't do so because he sensed that the creature before him had human

sentiments and that it would be immoral to shoot at it when his self-defense was not an issue.

The second witness, Marty Paddock reported pretty much the same thing. However, the creature was only 6 feet away when he initially encountered it. According to Mr. Paddock, it had eyes that were either red or pink, possessed a foul smell like rotten eggs, and that it screamed like a woman or pig when he first came across it. Mr. Paddock added that it had rugged, muscular build and could move very fast, while not actually running. His sighting occurred at about 10:00 p.m. the day before that of Officer Gosselin (August 24, 1976).

At some point during our meeting, Marty Paddock retrieved a plaster cast of the creature's footprint. It was made by Deputy Sheriff Glen La Rose of the Washington County Sheriff's Department two weeks before. This cast was measured and photographed by Benton Jamison. The total length from toe to heel was 19 and 1/2 inches; maximum width at the ball of foot was 7 and 1/2 inches; maximum width of the arch instep was 5 inches. The heel appeared to be rounded. Faint impressions of the toes were visible. The large toe was prominent. While indistinct, the witnesses claimed that only 3 additional toe prints were observed when the cast was made and that these toes were approximately of equal in size.

We also learned that several additional bigfoot sightings had been reported over the past several days; two by Arnold Mercier of Whitehall, and two more by Tom or (?) Bill Jones also of Whitehall. Still another sighting was reported by a New Jersey couple who were passing through Whitehall. Officer Gosselin claimed that these reports were called in to the local State Police Barracks.

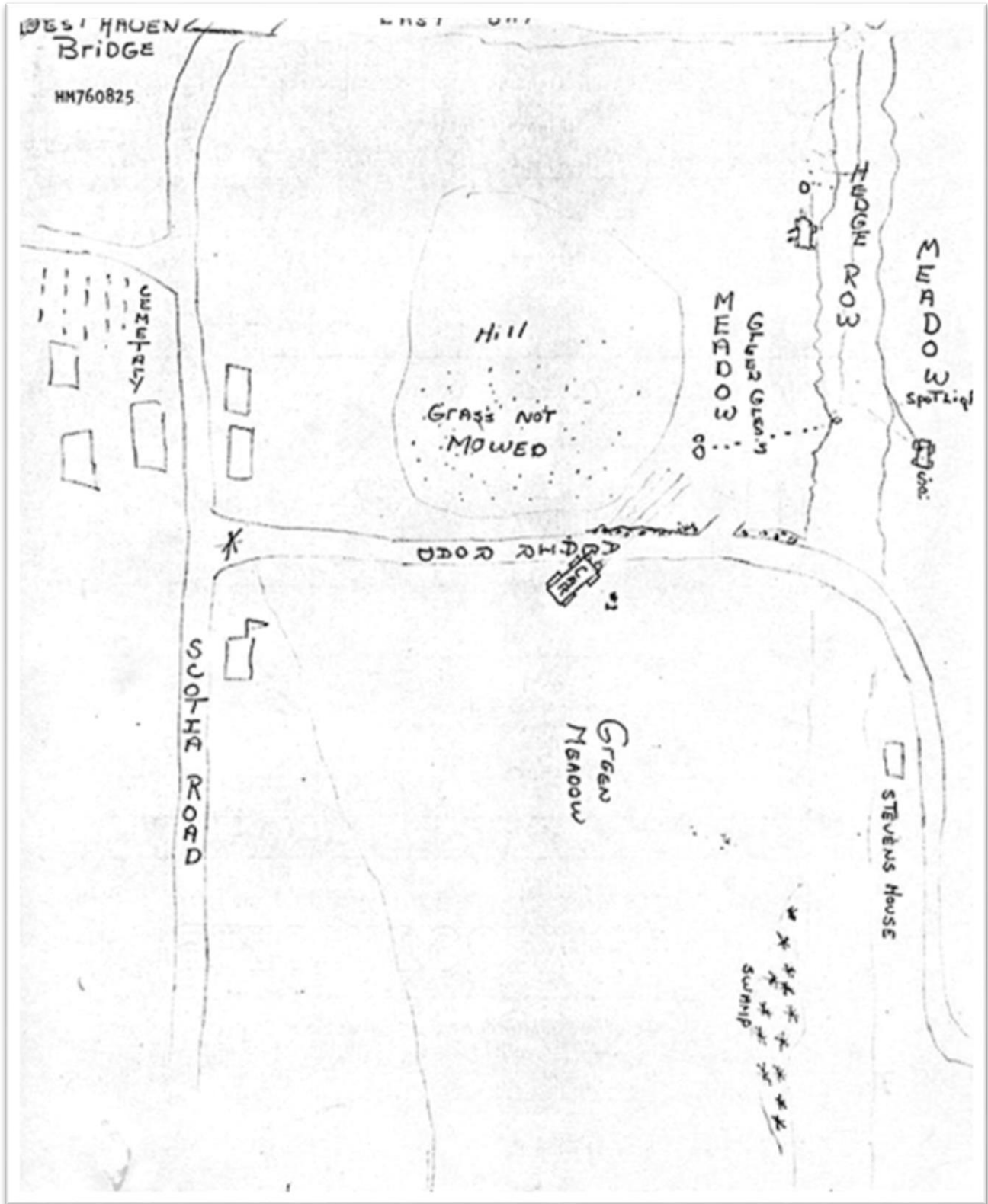

Do You Have Alien Blood? Mystery of Rh-Negative Blood

BLOOD GROUPS – GENERAL OVERVIEW

Nearly 85% of all human beings have RH positive blood. Which merely indicates that their red blood cells contain a substance called the Rhesus (rhesus) blood factor. Simply put, their positive blood contains a protein that can be linked to the Rhesus monkey.

While It is not generally known from where the negative RH factor derived, there seems to be evidence exists that it arises from genetic experimentation a little over 5,000 years ago!

The highest concentration of RH negative blood occurs in the Basque people of Northern Spain and Southern France, and in the Eastern/Oriental Jews.

While it is known that RH negative blood – (type 'O') is the purest blood known to mankind, it is not known from where the negative factor originates, as it is generally theorized by that there is an unbroken bloodline from early human prototypes (pre-humans) to present day human beings.

As previously mentioned, 'Rh negative' blood indicates no protein connections exist to the Rhesus monkey, whereas 'Rh positive' blood does carry protein linked to the Rhesus monkey – hence the 'Rh' designation, ie. rhesus. All other earthly primates have this RH factor. Thus, if all humans evolved from that line, all would have the RH factor. Obviously, that is not the case. Therefore, there must have been some manner of intervention giving rise to Rh-negative blood groups.

While the protein in positive blood can be cloned, that of negative blood cannot – which is quite interesting, and may be indicative of an alien origin, or more probable, from early genetic experimentation during previous advanced human civilizations.

Geneticists generally claim the Rh-negative factor is a mutation of unknown origin which apparently happened only a few thousand years ago. These 'negative' blooded people spread heavily into the area of what is now Spain, England, Ireland, France and later into America, Canada and Australia. Basque peoples contain the largest concentration of known 'O' negative blooded people today because, they for the most part, have confined themselves to one area, whereas the Celtic people have branched out among all of the new world.

WHAT THE ABSENCE OF RHESUS MONKEY FACTOR MEANS:

No solid scientific explanation exists as to how or why Rh- blood came about. It is presumed to be the result of a random mutation. Have you ever felt you were weird or different? It may be due to your DNA ... 85% of humans have the monkey gene (RH+) and 15% do not (RH-) and maybe have an alien gene instead. RH- people are characterized by higher IQs, sensitive vision, lower body temperatures, sensitivity to heat and sunlight, psychic power, ability to stop watches and electrical appliances and having extra vertebrae. We need to explore the possibility that we were bred as a slave race for labor, since 97% of our genetic code is disabled, with only 3% left for us to survive.

RH NEGATIVE BLOOD

Interestingly, popular sciences endeavor to attribute Rh-neg blood groups to "mutations." A solid alternative case may be extended to the conclusion that Rh-neg is NOT a mutation, but possibly the original human blood group. This, however, does not reflect tenured thought, and thus has never been adequately researched.

That there was a group of "pure" humans, not directly related to the evolutionary processes on Earth, is a distinct possibility. This reasoning would suggest that the original humans on our planet were not directly

related to the apes, but at some point were "MADE" or "genetically engineered" to give such impression.

Perhaps it was never intended that the Rh-positives become the dominant species. That through some as yet undetermined epoch, it won out.

BLOOD TYPES CONSPIRACY & RH FACTOR

In ALL blood groups there exists a common microbe that in essence is THE LIFE FORCE ITSELF. During experiments, blood was heated to 700 degrees F and also put it in Liquid Nitrogen. This microbe which is visible only with a highly modified dark field microscope, was STILL ALIVE. Also, testing this on 'mummy dust', This microbe is STILL alive after 5000 years plus when the mummy dust is placed in a Ph perfect solution the same as the "live blood", it returns back to 'life'!

The Draco (Reptilian) with the "O" RH-blood has unique properties because of the polarity of the blood cells. Blood is electrically/magnetic/chemical based. The relationship of all three must be kept at a specific PH balance of 7.0 to 7.2. The problem with the "O" RH-systems is this, the stomach has TOO MUCH acid in it for proper digestion so they had to resort to taking the trace mineral in THRU THE SKIN aka 'sitting in a bath tub full of minerals'.

Then after generations of this type of eating the digestive systems ceased to function properly. This is why Type "O" blood groups have so much trouble with 'indigestion'. It's in your genes because of this Draco influence.

WHY YOU SHOULD AVOID BLOOD TRANSFUSIONS!

The main reason for this has to do with cellular/genetic/galactic memory of blood. This is coded into the entire structure of the blood. All the emotions that the donor has felt during his entire lifetime are part of the

blood. This cannot be filtered out. For example, if you get a heart of a man who died in a car accident, all the cells of that organ have the memory of the accident and every emotion that was felt while dying. These emotions confuse your own coding and then mass internal confusion happens at the cellular level and the order turns into chaos.

THE PH REGULATORY SYSTEM OF THE BODY

The pH balance of the human bloodstream is recognized by all medical physiology texts as one of the most important biochemical balances in all of human body chemistry.

pH is the acronym for "Potential Hydrogen". In definition, it is the degree of concentration of hydrogen ions in a substance or solution. It is measured on a logarithmic scale from 0 to 14. Higher numbers mean a substance is more alkaline in nature and there is a greater potential for absorbing more hydrogen ions. Lower numbers indicate more acidity with less potential for absorbing hydrogen ions.

Our body pH is very important because pH controls the speed of our body's biochemical reactions. It does this by controlling the speed of enzyme activity as well as the speed that electricity moves through our body. The higher (more alkaline) the pH of a substance or solution, the more electrical resistance that substance or solution holds. Therefore, electricity travels slower with higher pH. All biochemical reactions and electrical (life) energy is under pH control.

If we say something has an acid pH, we are saying it is hot and fast. As an example, look at the battery of your car. It's an acid battery. On cold days, you want it to be hot and ready, and you want your car to start fast. Alkaline pH on the other hand, biochemically speaking, is slow and cool. Compare it to an alkaline battery in a flashlight. You want that battery to be cool, and to burn out slowly.

RH NEGATIVE BLOOD GROUPS

The Basque people of Spain and France have the highest percentage of Rh negative blood. About 30% have (rr) Rh negative and about 60% carry one (r) negative gene. The average among most people is only 15%-Rh negative, while some groups have very little. The Oriental Jews of Israel, also have a high percent Rh negative, although most other Oriental people have only about 1% Rh negative. The Samaritans and the Black Cochin Jew also have a high percentage of Rh negative blood, although again the Rh-negative blood is rare among most black people.

The Basque people are also known for having the oldest language in Europe, and the origins of the Basque language are unknown. The languages in neighboring countries in Europe show no resemblance to the Basque language, so this has become a real mystery to the linguist.

The Celtic people of Ireland and Great Britain also have high incidences of the Rh-Negative factor and it has recently been proven that there is a genetic link between the Basque and the Celts. This research proves that the Celtic people came from the Basque regions of France and Spain and a group must have migrated over to the islands of Great Britain.

Here are a few interesting facts shared by many within the Rhesus negative groups:

- A feeling of not belonging
- Truth seekers
- Sense of a "Mission" in life
- Empathy & Compassion for Mankind
- An extra rib or vertebra.
- Higher than average IQ
- ESP Ability
- Love of Space & Science
- More sensitive vision & other senses.
- Increased of psychic/intuitive abilities

- Cannot be cloned
- Lower body temperature
- Higher blood pressure (some say lower either way one extreme to another never quite right)
- Predominance of green or hazel eyes that change color
- Red or reddish tint to hair color
- Increased sensitivity to heat & sunlight
- Unexplained Scares
- Piercing Eyes
- Tend to be Healers
- Empathetic Illnesses
- Ability to disrupt electrical devices
- Prone to Alien Abductions
- Experience unexplained phenomenon
- Physic dreams and/or Ability

(Does this bring to mind the Indigo Children?)

AND NOW FROM RICHARD BONENFANT, PH.D:

An ongoing attempt is being made by abduction researchers to determine the possible significance of the Rh-O blood type among experiencers. This effort also attempts to determine possible attributes associated with this blood type.

To date, the results of these efforts have been tantalizing but not definitive. A larger collection of experiencers would greatly help define the study's outcome. However, regardless of the presence of a correlation, it is vital to continue efforts of this type. The abduction community must unite in their efforts to understand the nature of this phenomenon by advancing and supporting research similar to that presented above. It's presently doubtful that the scientific community will respect this effort until we are able to speak their language.

Ex-CIA Official Says Stories of Crashed UFOs and Little Grey Men “on Ice” Discussed at a High-Level

Victor Marchetti, the former Special Assistant to CIA Director Richard Helms, first mentioned that rumors of recovered UFOs and dead aliens had been circulating among high-level agency staffers in a 1979 [article in Second Look magazine](#), although most people are completely unaware of this fact.

Indeed, an online search for the article, titled “How the CIA Views the UFO Phenomenon”, yields very few results. So while the Internet provides access to vast numbers of UFO-related documents, books, articles and blogs, one of the most important pieces ever written on the topic, authored by a knowledgeable government insider, has been almost completely overlooked.

It has long been reported that there were efforts to block Marchetti's revelations from being made more accessible online.

In any case, Marchetti's groundbreaking article contains important information about the CIA's secret involvement, as well as its self-proclaimed non-involvement, with the UFO phenomenon. He writes, “I do know that the CIA and U.S. Government have been concerned over the UFO phenomenon for many years and that their attempts, both past and recent, to discount the significance of the phenomenon and to explain away the apparent lack of official interest in it have all the earmarkings of a classic intelligence cover-up.”

To give you a sense of the author's importance, the agency once fought Marchetti all the way to the U.S. Supreme Court, to attempt to stop the publication of his book, “The CIA and the Cult of Intelligence”, which subsequently became a best-seller in 1974. The disenchanted agency man had resigned from the CIA in 1969; his book was an unprecedented, historic exposé of his former employer's numerous illegal activities—

including spying on Americans, something forbidden by its charter—many of which were later investigated by Congress.

Marchetti was especially dangerous to the CIA simply because he knew so much about its operations, legal or otherwise, and was determined to reveal them to the world as a partial antidote.

While this same informed-observer status and careful, thoughtful analysis underpins Marchetti's revelations about the agency's relationship to UFOs, it must be remembered that the CIA's routine use of compartmentalization, designed to limit any given individual's knowledge to one small part of a project or operation, meant that only a very few high-level managers were aware of the big picture. This *modus operandi* was also applied to the topic of UFOs and, therefore, Marchetti could only report on what he personally knew, as opposed to providing an overview, given that he was not directly involved with the agency's apparent UFO projects/operations and had no need-to-know about them.

Nevertheless, his published comments are noteworthy. He writes:

During my years in the CIA, UFOs were not a subject of common discussion. But neither were they treated in a disdainful or derisive manner, especially not by the agency's scientists. Instead, the topic was rarely discussed at internal meetings. It seemed to fall into the category of 'very sensitive activities' ... People simply did not talk about the UFO phenomenon.

There were, however, rumors at high levels of the CIA—rumors of ... little grey men whose ships had crashed, or had been shot down, being kept 'on ice' by the Air Force at FTD (the Foreign Technology Division) at Wright-Patterson Air Force Base in Dayton, Ohio.

Again, Marchetti's use of the word "rumors" results from his own non-involvement in the "very sensitive activities" CIA had in play relating to the UFO phenomenon. Consequently, whatever information Marchetti was

privity to derived from informal and probably unauthorized conversations he had with others at CIA headquarters.

But if accounts of crashed UFOs and alien bodies in cold storage were indeed discussed at "high levels" within the agency, one might reasonably infer that those stories were being taken seriously.

It will be remembered that, late in his career, U.S. Senator and Republican Presidential Candidate Barry Goldwater publicly revealed that he had learned of an above-Top Secret facility at Wright-Patterson, designated "the Blue Room", in which alien bodies and/or UFO wreckage resided. Goldwater said he had approached several Air Force Chiefs of Staff over time, in an attempt to gain access, only to be repeatedly rebuffed. So persons other than high-level CIA staffers had heard the "little grey men on ice" rumors.

One important aspect of Marchetti's revelations is the time-frame of the sensitive discussions at the CIA. Marchetti resigned in 1969, nearly a decade before the seminal disclosures by retired U.S. Army counterintelligence officer Jesse Marcel who, during a television interview in 1978, divulged that he had held in his hands wreckage from a craft "not of this Earth" that had crashed northwest of Roswell Army Air Field in July 1947.

A number of UFO debunkers have dismissed the UFO recovery story as a "modern myth" originating as a result of an overly-excited public's fascination with the writings of Stanton Friedman, Bill Moore, and others in the 1979-80 time-frame, all of whom incorporated Marcel's remarks about his involvement in the discovery of the mysterious wreckage in 1947.

However, in light of Marchetti's revelations, this theory simply does not work. Given his resignation from CIA in 1969, he had to have heard those high-level rumors about crashed UFOs and dead aliens stored at Wright-Patterson prior to that time. Therefore, many years before Roswell became a cultural phenomenon, in the early 1980s, hard-nosed CIA

officers were privately discussing the crashed UFO topic among themselves.

Importantly, confirmation of the Roswell event has been provided by another credible person, USAF Brigadier General Arthur E. Exon, who has stated for the record that one or more plane-loads of wreckage did indeed arrive at Wright Field (later renamed Wright-Patterson Air Force Base) shortly after its discovery in New Mexico and was subjected to intense analysis by aeronautical engineers. During an audiotaped interview with Roswell researcher Dr. Kevin D. Randle, in 1990, Exon said, "... They knew they had something new in their hands. The metal and material was unknown to [everyone] I talked to. Whatever they found, I never heard what the [analytical] results were. A couple of guys thought it might be Russian, but the overall consensus was that the pieces were from space. Everyone from the White House on down knew that what we had found was not of this world within 24 hours of our finding it ... Roswell was the recovery of a craft from space."

All of General Exon's published comments regarding the matter may be read [here](http://roswellproof.homestead.com/exon.html). <http://roswellproof.homestead.com/exon.html>

In his article, Marchetti theorizes that the primary reason underlying the U.S. government's refusal to acknowledge the reality of UFOs, if indeed the craft are piloted by alien beings, results from its fear that existing power structures would be fundamentally undermined by such an admission. He writes,

"... the U.S. Government, in collusion with other national powers of the Earth, is determined to keep this information from the general public. The purpose of the international conspiracy is to maintain a workable stability among the nations of the world and for them, in turn, to retain institutional control over their respective populations. Thus, for these governments to admit there are beings from outer space attempting to contact us, beings with mentalities and technological capabilities obviously far superior to

ours, could, once fully perceived by the average person, erode the foundations of the Earth's traditional power structure.

Political and legal systems, religions, economic and social institutions could all soon become meaningless in the mind of the public. The national oligarchical establishments, even civilization as we know it, could collapse into anarchy."

Such extreme conclusions are not necessarily valid, but they probably accurately reflect the fears of the "ruling class" of the major nations, whose leaders (particularly those in the intelligence business) have always advocated excessive governmental secrecy as being necessary to preserve "national security." The real reason for such secrecy is, of course, to keep the public uninformed, misinformed, and, therefore, malleable.

Additional Experts Reveal Alien Truth's

"I can assure you that flying saucers, given that they exist, are not constructed by any power on Earth."

--President Harry Truman, April 4, 1950 White House press conference

"For the next two or three days the saucers passed over the base daily. Sometimes they appeared in groups of four, other times as many as sixteen. They could outmaneuver and outflank us seemingly at will. They moved at varying speeds - sometimes very fast, sometimes slow - and other times they would come to a dead stop as we zoomed past underneath."

--Astronaut Gordon Cooper, describing his first direct encounters with UFO's while serving as a military pilot in Germany

"It was a four-foot human shaped figure with arms, bizarre-looking four-fingered hands... and an oversized incandescent lightbulb-shaped head... pale grey skin...But the eye sockets themselves were oversized and almond shaped and pointed down to its tiny nose, which didn't protrude from the skull."

--Eisenhower White House National Security Council staff member Col. Philip J. Corso describing dead aliens he saw in glass containers en route from Roswell, NM to Wright Field in Ohio

"These (grey aliens) were living, breathing creatures, just as mortal as you and I. They had feelings, they had families. They had a cultural society. The one thing they didn't have was hate, hostility. They had anger, from what I observed - and I don't know how to explain it better than stating - it was an intellectual anger. They could not... comprehend how a species such as us, that had such great potential to do such wonderful and

marvelous things, could do such horrible and nightmarish things to one another."

--Master Sgt. Clifford Stone, ret., who testified that he encountered "grey" aliens while working in a US Army unit that retrieved crashed extraterrestrial vehicles

"UFOs are conceived and directed by intelligent beings of a very high order, and they are propelled by distorting the gravitational field, converting gravity into usable energy.

"There is no doubt in my mind that these objects are interplanetary craft of some sort. I and my colleagues are confident that they do not originate in our solar system, but we feel that they may use Mars or some other body as sort of a way station. They probably do not originate in our solar system, perhaps not even in our galaxy."

"We cannot take the credit for our record advancement in certain scientific fields alone. We have been helped by the people of other worlds "

--Dr. Herman J. Oberth, a father of rocketry and modern astronautics

"We find ourselves faced by powers which are far stronger than we had hitherto assumed, and whose base is at present unknown to us. More I cannot say at present. We are now engaged in entering into closer contact with those powers, and in six or nine months' time it may be possible to speak with some precision on the matter."

--Dr. Wernher von Braun, the first Director of NASA

"UFOs sighted in Indonesia are identical with those sighted in other countries. Sometimes they pose a problem for our air defense and once we were obliged to open fire on them."

--Air Marshall Roesmin Nurjadin, Commander-in-Chief of the Indonesian Air Force

"Much evidence tells us UFOs have been tracked by radar; so, UFOs are real and they may come from outer space UFO photographs and various materials show scientifically that there are more advanced people piloting the saucers and motherships."

--General Kanshi Ishikawa, Chief of Staff of Japan's Air Self-Defense Force

"I believe that UFOs are spaceships or extraterrestrial craft The nations of the world are currently working together in the investigation of the UFO phenomenon. There is an international exchange of data. Maybe when this group of nations acquires more precise and definite information, it will be possible to release the news to the world."

--General Carlos Castro Caverro, Spanish Air Force

"In any case, the Air Force has arrived to the conclusion that a certain number of anomalous phenomena has been produced within Belgian airspace. The numerous testimonies of ground observations compiled ... reinforced by the reports of the night of March 30-31 [1990], have led us to face the hypothesis that a certain number of unauthorized aerial activities have taken place

"The day will come undoubtedly when the phenomenon will be observed with technological means of detection and collection that won't leave a single doubt about its origin. This should lift a part of the veil that has covered the mystery for a long time. A mystery that continues to the present. But it exists, it is real, and that in itself is an important conclusion."

--Major-General Wilfred de Brouwer, Deputy Chief of the Royal Belgian Air Force

"The problem of 'flying discs' has polarized the attention of the whole world, but it's serious and it deserves to be treated seriously. Almost all the governments of the great powers are interested in it, dealing with it in a serious and confidential manner, due to its military interest."

"It is impossible to deny any more the existence of flying saucers at the present time. The flying saucer is not a ghost from another dimension It is a fact confirmed by material evidence."

--Brigadier General João Adil Oliveira, Chief of the Air Force General Staff Information Service, Brazil

"The number of thoughtful, intelligent, educated people in full possession of their faculties who have 'seen something' and described it, grows every day We can ... say categorically that mysterious objects have indeed appeared and continue to appear in the sky that surrounds us."

--General Lionel M. Chassin, Commanding General of the French Air Force

"I must say that if listeners could see for themselves the mass of reports coming in from the airborne gendarmerie [a body of soldiers serving as armed police], from the mobile gendarmerie, and from the gendarmerie charged with the job of conducting investigations, all of which reports are forwarded by us to the National Center for Space Studies, then they would see that it is all pretty disturbing."

--M. Robert Galley, French Minister of Defense

"Taking into account the facts that we have gathered from the observers and from the location of their observations, we concluded that there generally can be said to be a material phenomenon behind the observations. In 60% of the cases reported here, the description of this

phenomenon is apparently one of a flying machine whose origin, modes of lifting and/or propulsion are totally outside our knowledge."

--Dr. Claude Poher, astronomer, founder and first director of GEPAN, the UFO investigative office under the French government's National Center for Space Sciences

"The evidence that there are objects which have been seen in our atmosphere, and even on terra firma, that cannot be accounted for either as man-made objects or as any physical force or effect known to our scientists, seems to me to be overwhelming

"A very large number of sightings have been vouched for by persons whose credentials seem to me unimpeachable. It is striking that so many have been trained observers, such as police officers and airline or military pilots. Their observations have in many instances ... been supported either by technical means such as radar or, even more convincingly, by ... interference with electrical apparatus of one sort or another"

--Lord Hill-Norton, Chief of Defense Staff, Ministry of Defense, Great Britain

"More than 10,000 sightings have been reported, the majority of which cannot be accounted for by any 'scientific' explanation I am convinced that these objects do exist and that they are not manufactured by any nation on Earth.

"I can therefore see no alternative to accepting the theory that they come from some extraterrestrial source."

"Of course flying saucers are real -- and they are interplanetary."

"There are many reasons to believe that they (UFOs) do exist: there is so much evidence from reliable witnesses."

--Air Chief Marshal Lord Dowding, Commander-in-Chief of the Royal Air Force Fighter Command during the Battle of Britain

"It followed us during half of our orbit. We observed it on the light side, and when we entered the shadow side, it disappeared completely.

"It was an engineered structure, made from some type of metal, approximately 40 meters long with inner hulls. The object was narrow here and wider here, and inside there were openings. Some places had projections like small wings. The object stayed very close to us. We photographed it, and our photos showed it to be 23 to 28 meters away."

--Cosmonaut Victor Afanasyev (speaking about a sighting that occurred en route to the Solyut 6 space station in April of 1979)

"You now face a new world, a world of change. We speak in strange terms, of harnessing the cosmic energy, of ultimate conflict between a united human race and the sinister forces of some other planetary galaxy.

"The nations of the world will have to unite, for the next war will be an interplanetary war. The nations of the earth must someday make a common front against attack by people from other planets."

--General Douglas MacArthur: 8 October 1955

"I certainly believe in aliens in space. They may not look like us, but I have very strong feelings that they have advanced beyond our mental capabilities."

"I think some highly secret government UFO investigations are going on that we don't know about, and probably never will unless the Air Force discloses them."

--Major General and Senator Barry Goldwater

"The Federal Bureau of Investigation has been requested to assist in the investigation of reported sightings of flying disks ..."

"I would do it, but before agreeing to do it we must insist upon full access to discs recovered. For instance in the LA case the Army grabbed it and would not let us have it for cursory examination."

--Edgar Hoover, Director of the FBI

"If you suppress the truth it becomes your enemy ... if you expose the truth it becomes your weapon.

"I had the evidence that a crash did happen [at Roswell, New Mexico, 1947]. I ask you this, were you there with me? Did you have the clearances? They can't answer these questions, they simply criticize with no evidence."

--Colonel Philip Corso, U. S. Army

"No agency in this Country or Russia is able to duplicate at this time the speeds and accelerations which radars and observers indicate these flying objects are able to achieve Reliable reports indicate there are objects coming into our atmosphere at very high speeds and controlled by thinking intelligences."

--Admiral Delmer S. Fahrney, former head of the U. S. Navy's guided-missile program

"This 'flying saucer' situation is not at all imaginary or seeing too much in some natural phenomena. Something is really flying around."

"The phenomena reported is something real and not visionary or fictitious.

"There are objects probably approximately the shape of a disc, of such appreciable size as appear to be as big as man-made aircraft.

"The reported operating characteristics, such as extreme rate of climb, maneuverability (particularly in roll) ... must be considered evasive when sighted or contacted by friendly aircraft or radar."

"... some of the objects are controlled either manually, automatically or remotely.

"The apparent common description of the objects is ... metallic or light reflecting surface ... Circular or elliptical in shape ... Flat on bottom and domed on top."

"... Headquarters, Army Air Forces issue a directive assigning a priority, security classification and Code Name for a detailed study of this matter ..."

--General Nathan Twining, Chief of Staff of the U. S. Air Force and Chairman of the Joint Chiefs of Staff

"We have, indeed, been contacted -- perhaps even visited -- by extraterrestrial beings, and the US government, in collusion with the other national powers of the Earth, is determined to keep this information from the general public."

--Victor Marchetti, former Special Assistant to the Executive Director of the Central Intelligence Agency

"Unknown objects are operating under intelligent control It is imperative that we learn where UFOs come from and what their purpose is. Behind the scenes, high-ranking Air Force officers are soberly concerned about UFOs. Through official secrecy and ridicule, many citizens are led to believe that unidentified flying objects are nonsense. To hide the facts the Air Force has silenced its personnel."

"It is time for the truth to be brought out in open Congressional hearings. Behind the scenes high-ranking Air Force officers are soberly concerned about the UFOs. But through official secrecy and ridicule, many citizens are led to believe the unknown flying objects are nonsense I urge

immediate Congressional action to reduce the dangers from secrecy about unidentified flying objects."

--Vice Admiral Roscoe H. Hillenkoetter, former Director of the Central Intelligence Agency

"Maximum security exists concerning the subject of UFOs."

--Former CIA Director Allen Dulles

"The American public deserves a better explanation than that thus far given by the U. S. Air Force."

"I strongly recommend that there be a committee investigation of the UFO phenomena. I think we owe it to the people to establish credibility regarding UFOs and to produce the greatest possible enlightenment on this subject."

--President Gerald R. Ford (in the only public statement he has ever made about UFOs)

"I don't laugh at people any more when they say they've seen UFOs. I've seen one myself.

"It was the darndest thing I've ever seen. It was big; it was very bright; it changed colors and it was about the size of the moon

"We watched it for ten minutes, but none of us could figure out what it was. One thing's for sure, I'll never make fun of people who say they've seen unidentified objects in the sky.

"If I become President, I'll make every piece of information that this Country has about UFO sightings available to the public and scientists."

--President Jimmy Carter (as Governor of Georgia)

"I was in a plane last week when I looked out the window and saw this white light. It was zigzagging around.

"I went up to the pilot and said, 'Have you ever seen anything like that?' He was shocked and he said, 'Nope.' And I said to him, 'Let's follow it!'

"We followed it for several minutes. It was a bright white light.

"We followed it to Bakersfield, and all of a sudden to our utter amazement it went straight up into the heavens.

"When I got off the plane I told Nancy all about it. But we didn't file a report on the object because for a long time they considered you a nut if you saw a UFO"

--President Ronald Reagan (as Governor of California, in 1974)

"I saw live video feed of an 8-9 ft. tall non-human working alongside two human astronauts in the Space Shuttle's open bay while the alien's wing-shaped craft hovered nearby"

--Clark McClelland, who worked on NASA's space shuttle program until 1992

"I have no idea what it could be," and described it as "... greyish in color and about thirty to forty feet away."

Major White exclaimed over the radio: "There are things out there! There absolutely is!"

--Major Robert White, USAF X-15 test pilot, reported a UFO on 17 July 1962 at a height of 58 miles during an X-15 flight

"I was testing a P-51 fighter in Minneapolis when I spotted this object. I was at about 10,000 feet on a nice, bright, sunny afternoon. I thought the object was a kite, then I realized that no kite is going to fly that high. As I

got closer it looked like a weather balloon, grey and about three feet in diameter. But as soon as I got behind the darn thing it didn't look like a balloon anymore. It looked like a saucer, a disk.

"About the same time, I realized that it was suddenly going away from me and there I was, running at about 300 miles per hour. I tracked it for a little way, and then all of a sudden, the damn thing just took off. It pulled about a 45-degree climbing turn and accelerated and just flat disappeared."

--Dr. Donald Slayton, Mercury astronaut

"The U.S. Government hasn't maintained secrecy regarding UFOs; it's been leaking out all over the place. But the way it's been handled is by denial, by denying the truth of the documents that have leaked. By attempting to show them as fraudulent, as bogus of some sort.

"There has been a very large disinformation and misinformation effort around this whole area. And one must wonder, how better to hide something out in the open than just to say, 'It isn't there. You're deceiving yourself if you think this is true.' And yet, there it is right in front of you.

"So it's a disinformation effort that's concerning here, not the fact that they have kept the secret. They haven't kept it. It's been getting out into the public for fifty years or more."

"By becoming more involved with the serious research field, I've seen the evidence mount towards the truth of these matters.... We cannot say that today's government is really covering it up; I think that most of them don't know what is going on any more than the public"

"I've talked with people of stature -- of military and government credentials and position -- and heard their stories, and their desire to tell their stories openly to the public

"The first-hand experiences of these credible witnesses that, now in advanced years are anxious to tell their story, we can't deny that, and the

evidence points to the fact that Roswell was a real incident, and that indeed an alien craft did crash, and that material was recovered from that crash site."

--Astronaut Mitchell also stated (in 1971): "We all know UFOs are real. All we need to ask is where are they from."

--Dr. Edgar Mitchell, Apollo 14 astronaut and the sixth man on the moon

"Also, I did have occasion in 1951 to have two days of observation of many flights of them, of different sizes, flying in fighter formation, generally from east to west over Europe. They were at a higher altitude than we could reach with our jet fighters at that time."

Colonel Cooper reported some years later, as an astronaut in orbit, that a green UFO had passed by his space capsule going east to west (in the opposite direction of NASA's orbits) in May of 1963. The object was simultaneously tracked from the ground in Perth, Australia.

NASA subsequently told the press that it was forbidden to question astronaut Cooper about the incident.

Colonel Cooper later stated to the United Nations (in a letter of 9 November 1978): "I believe that these extraterrestrial vehicles and their crews are visiting this planet from other planets which obviously are a little more technically advanced than we are here on Earth. I feel that we need to have a top level, coordinated program to scientifically collect and analyze data from all over the Earth concerning any type of encounter, and to determine how best to interface with these visitors in a friendly fashion."

"I am somewhat qualified to discuss them, since I have been into the fringes of the vast areas in which they travel.

Colonel Cooper also said: "For many years I have lived with a secret, in a secrecy imposed on all specialists and astronauts. I can now reveal that every day, in the USA, our radar instruments capture objects of form and

composition unknown to us. And there are thousands of witness reports and a quantity of documents to prove this, but nobody wants to make them public."

Colonel Cooper later added (on 14 January 1997): "I know other astronauts share my feelings And we know the government is sitting on hard evidence of UFOs."

Colonel Cooper stated on another occasion: "I had a good friend at Roswell, a fellow officer. He had to be careful about what he said. But it sure wasn't a weather balloon, like the Air Force cover story. He made it clear to me what crashed was a craft of alien origin, and members of the crew were recovered."

--Colonel L. Gordon Cooper, one of the original Mercury 7 astronauts and Command Pilot on the Gemini 5 mission

"At one stage we even thought it might be necessary to take evasive action to avoid a collision." (referring to one of three encounters he and astronaut Ed White had with UFOs that approached their orbiting space capsule)

--Astronaut Brigadier General James McDivitt, Command Pilot on Gemini 4 and Commander of Apollo 9

"... I've been asked about UFOs and I've said publicly I thought they were somebody else, some other civilization."

--Commander Eugene Cernan, Commander of the Apollo 17 Mission

"Statistically it's a certainty there are hugely advanced civilizations, intelligences, life forms out there. I believe they're so advanced they're even doing interstellar travel. I believe it's possible they even came here."

Later, in Honolulu, Hawaii, astronaut Musgrave revealed much more when he pointed to an artist's drawing of a small, thin, grey-colored extraterrestrial with large black almond-shaped eyes and stated emphatically: "They are out there!"

--Astronaut Story Musgrave, Dean of American Astronauts (who has flown in all 5 of the Columbia, Challenger, Atlantis, Discovery and Endeavor Space Shuttles

"At no time when the astronauts were in space were they alone; there was a constant surveillance by UFOs."

--Astronaut Scott Carpenter, one of the original Mercury 7 astronauts and Executive Assistant to the Director of NASA's Manned Space Flight Center (who photographed a UFO while in orbit on 24 May 1962 NASA still refuses to release the photograph)

"For nearly fifty years, the secrecy apparatus within the United States Government has kept from the public UFO and alien contact information."

Then the astronaut added: "We have contact with alien cultures."

--Dr. Brian O'Leary, former NASA astronaut and Assistant Professor of Astronomy at Cornell University

The public heard the astronauts report a "light" on a crater, followed by a request by NASA for more information. At that point, the television transmission was censored and the public heard nothing further.

Here, however, is the beginning of the actual exchange censored by NASA:

NASA: "What's there? Mission Control calling Apollo 11"

Apollo 11: "These "babies" are huge, sir! Enormous! Oh, my God! You

wouldn't believe it! I'm telling you there are other spacecraft out there, lined up on the far side of the crater edge! They're on the Moon watching us!"

--Astronaut Neil Armstrong, command pilot for Gemini 8 and Commander of Apollo 11, and Colonel Edwin "Buzz" Aldrin, Ph.D., the first and second men to step on the moon, both encountered alien spacecraft shortly after their moon landing on 21 July 1969

"We seek a free flow of information We are not afraid to entrust the American people with unpleasant facts, foreign ideas, alien philosophies, and competitive values."

"For a nation that is afraid to let its people judge the truth and falsehood in an open market is a nation that is afraid of its people."

--The words of President John F. Kennedy, Spoken on 21 November 1963, before his assassination on the following day

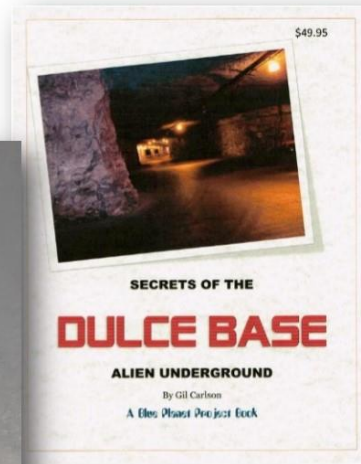
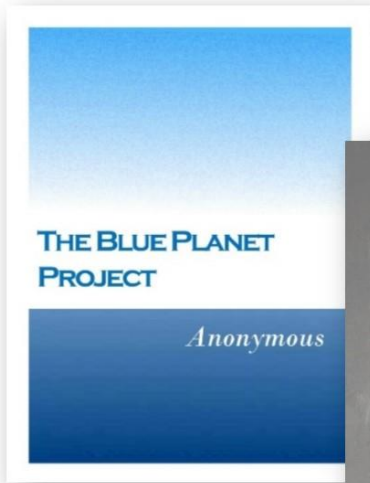

More Books in the Blue Planet Project Series
Check out the website:

www.blue-planet-project.com/

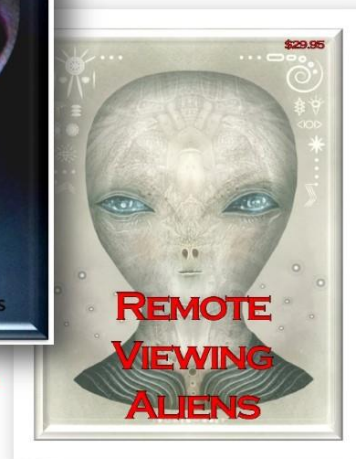

Each book is also available
on **Amazon.com**

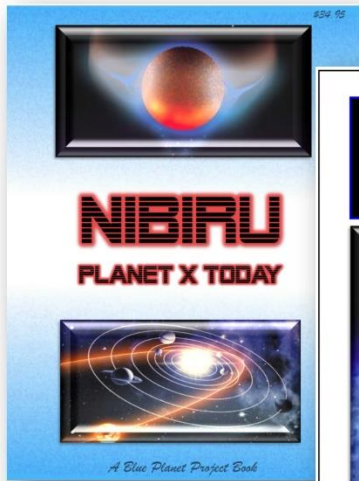

More Books in the Blue Planet Project Series
Check out the website:

www.blue-planet-project.com/

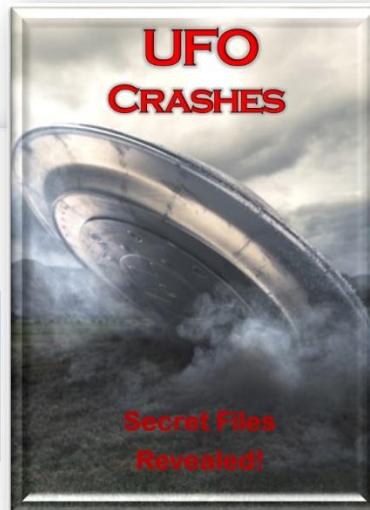

Each book is also available
on **Amazon.com**