

7081 227-01

IKV 511

LIEBHERR

Disposal notes

The appliance contains some reusable materials and should be disposed of properly - not simply with unsorted household refuse. Appliances which are no longer needed must be disposed of in a professional and appropriate way, in accordance with the current local regulations and laws.



When disposing of the appliance, ensure that the refrigeration circuit is not damaged to prevent uncontrolled escape of the refrigerant it contains (data on type plate) and oil.

- Disable the appliance.
- Pull out the plug.
- Cut through the connecting cable.

! WARNING

Danger of suffocation due to packing material and plastic film! Do not allow children to play with packing material. Take the packing material to an official collecting point.

Range of appliance use

The appliance is suitable solely for cooling food in a domestic environment or similar. This includes use in, for example

- in staff kitchenettes, bed and breakfast establishments,
- by guests in country homes, hotels, motels and other forms of accommodation,
- in catering and similar services in the wholesale trade.

Use the appliance solely as is customary within a domestic environment. All other types of use are inadmissible. The appliance is not suitable for storing and cooling medicines, blood plasma, laboratory preparations or similar substances and products covered by the 2007/47/EC Medical Devices Directive. Misuse of the appliance can result in the stored products suffering harm or perishing. Furthermore, the appliance is not suitable for operation in potentially explosive atmospheres.

Description of appliance and equipment

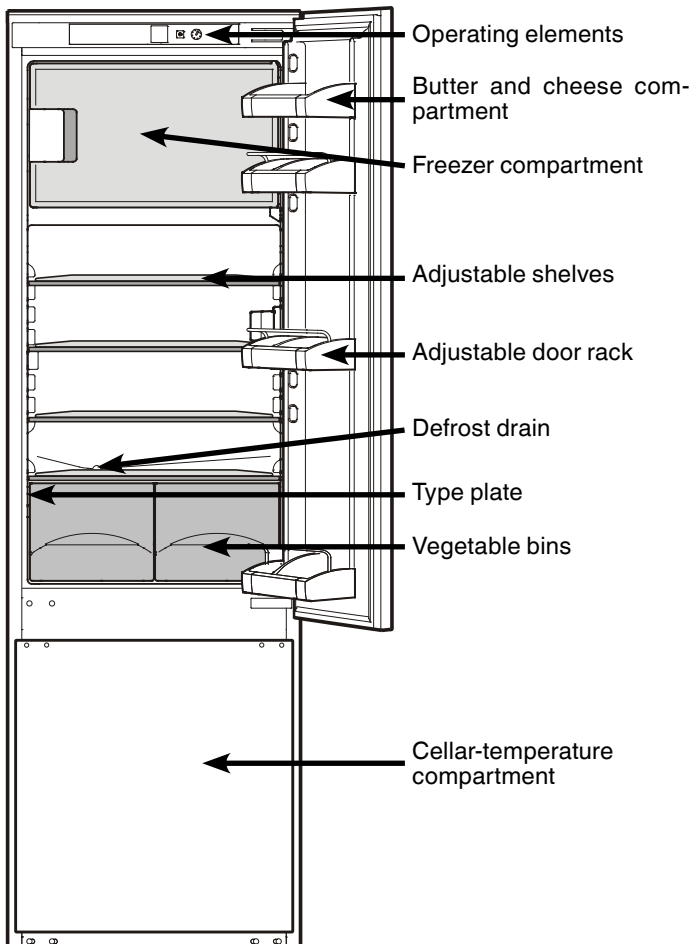

Safety instructions and warnings

- To prevent injury or damage to the unit, the appliance should be unpacked and set up by two people.
- In the event that the appliance is damaged on delivery, contact the supplier immediately before connecting to the mains.
- To guarantee safe operation, ensure that the appliance is set up and connected as described in these operating instructions.
- Disconnect the appliance from the mains if any fault occurs. Pull out the plug, switch off or remove the fuse.
- When disconnecting the appliance, pull on the plug, not on the cable.
- Any repairs and work on the appliance should only be carried out by the customer service department, as unauthorised work could prove highly dangerous for the user. The same applies to changing the mains power cable.
- Do not allow naked flames or ignition sources to enter the appliance. When transporting and cleaning the appliance ensure that the refrigerant circuit is not damaged. In the event of damage, make sure that there are no ignition sources nearby and keep the room well ventilated.
- Do not stand on the plinth, drawers or doors or use them to support anything else.
- This appliance is not intended for use by persons (including children) with reduced physical, sensory or mental capabilities or lack of experience and knowledge unless they have been given initial supervision or instruction concerning use of the appliance by a person responsible for their safety. Children should be supervised to ensure that they do not play with the appliance.
- Avoid prolonged skin contact with cold surfaces or chilled/frozen food. This could cause pain, numbness and frostbite. In the case of prolonged skin contact, protective measures should be taken, e.g. gloves should be worn.
- Do not eat ice cream, particularly ice lollies or ice cubes, immediately after taking them from the freezer compartment as there is a risk of "burning" because of the very cold temperatures.
- Do not consume food which has been stored for too long, as it could cause food poisoning.
- The appliance is designed for cooling, freezing and storage of food, and for making ice and is intended for domestic use. If used for commercial purposes, the relevant legal regulations applicable to the trade concerned must be observed.
- Do not store explosives or sprays using combustible propellants such as butane, propane, pentane etc. in the appliance. Electrical components might cause leaking gas to ignite. You may identify such sprays by the printed contents or a flame symbol.
- Do not use electrical appliances inside the appliance. Do not connect the appliance to the supply with other equipment using an extension cable. This can cause the extension socket to overheat.
- Special-purpose lamps (incandescent lamps, LEDs, fluorescent tubes) in the appliance serve to illuminate the appliance interior and are not suited for room illumination.

Remove all transit supports

Unscrew the red transport lock.

Close the vacated retaining hole using the plug.

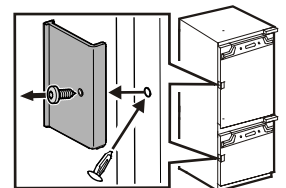

Setting up

- Standard EN 378 specifies that the room in which you install your appliance must have a volume of 1 m³ per 8 g of R 600a refrigerant used in the appliance, so as to avoid the formation of inflammable gas/air mixtures in the room where the appliance is located in the event of a leak in the refrigerant circuit. The quantity of refrigerant used in your appliance is indicated on the type plate on the inside of the appliance.
- Only use the appliance when it is installed.

Climate rating

The appliance is set to operate within specific ambient temperature limits according to its climate rating. These temperature limits should not be exceeded. The correct climate rating for your appliance is indicated on the type plate.

Climate rating	Ambient temperature
SN	+10°C to +32°C
N	+16°C to +32°C
ST	+16°C to +38°C
T	+16°C to +43°C

Connecting to the mains

Power supply (AC) and voltage at the operating point must comply with the details on the type plate, which is located inside the appliance on the left-hand side. The socket must be fused with a 10 A fuse or higher, it must be away from the rear of the appliance and must be easily accessible.

Connect the appliance with a properly earthed fused plug and socket only.

Saving energy

- Always ensure good ventilation. Do not cover ventilation openings or grille.
- Do not place appliance in areas of direct sunlight or next to a stove, heater or similar object.
- The energy consumption depends on the installation conditions, e.g. the ambient temperature.
- Keep the time the appliance is open to a minimum.
- Store food logically.
- Ensure that all food is well packed and covered for storage. This will prevent frost from forming.
- First cool warm food to room temperature before storing it.
- Defrost frozen food in the refrigerator.
- If there is a thick layer of frost in the appliance: defrost the appliance.

Operating elements

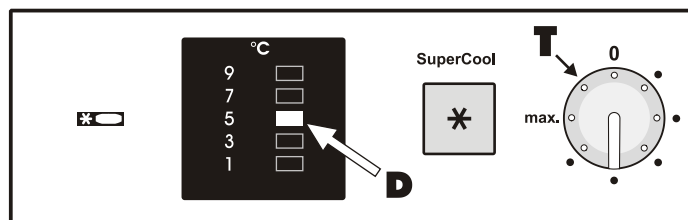

Switching the appliance on and off

You are recommended to clean the appliance before switching it on for the first time (see "Cleaning").

To switch the appliance on:

Connect the appliance to the mains - the appliance is switched on. The temperature display **D** shows the set interior temperature.

To switch the appliance off:

Pull out the mains plug or set the temperature control to "0".

Setting the temperature

The temperature can be set between the first point (warmest temperature, lowest refrigerating capacity) and max. (coldest temperature, highest refrigerating capacity).

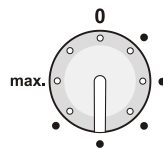

The recommended temperature is 5 °C i.e. a medium control setting. An average temperature of approx. -18 °C is then reached in the freezer compartment.

- Turn the temperature control **T** with a coin until the temperature wanted shines in the temperature display.

The temperature can be set slightly colder within a temperature range, e.g. 5 °C to 7 °C, or between two points of the control.

- If required, slowly turn the temperature control further.

The lit bar of the temperature range e.g. 5 °C to 7 °C flashes briefly. The temperature within the temperature range was set colder.

Supercool

The Supercool button switches the refrigerator compartment to maximum cooling. This is recommended particularly if you wish to cool large quantities of fresh food as fast as possible.

Switching on: Press the Supercool button briefly so that the LED comes on.

Note: The Supercool function uses more energy. After approx. 6 hours, however, the electronic system automatically switches back to normal energy-saving operation.

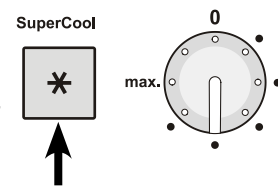

Pull-out compartment with cellar temperatures

Suitable for storing cold-sensitive vegetables, tropical fruit and any food or drink you do not wish to consume too cold. The temperature in the cellar temperature compartment is about 5°C higher than the temperature set in the refrigerator compartment.

- ⑤ Bottle container
- ⑥ Container for vegetables and tropical fruits
- ⑦ Container for small fruits and vegetables

For cleaning, remove the container ⑤ by simply lifting it.

To remove the container ⑥, pull it out completely, lift it at the back and pull it out towards you.

Container ⑦ is fastened with screws.

To insert container ⑥ :

- Extend the pull-out rails as far as they will go.
- Place the container on the rails and slide it in.

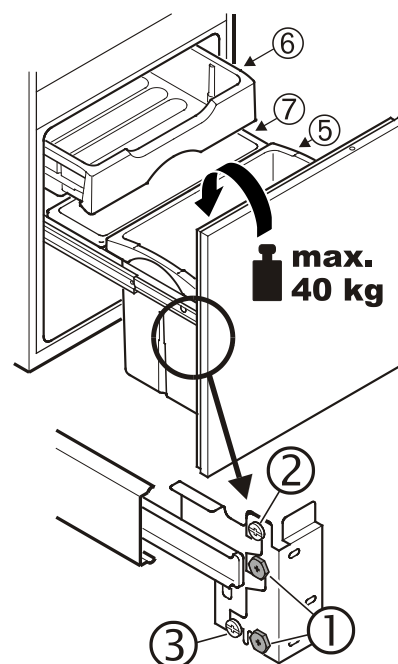

Adjusting appliance door

- Slacken screws ① right and left.
- Adjust door angle with setscrew ② and height with setscrew ③.
- Fasten appliance door with screws ①.

Equipment

You can re-arrange the **storage shelves** as required.

Lift the glass shelf, align the recess over the support and replace the shelf in a higher or lower position.

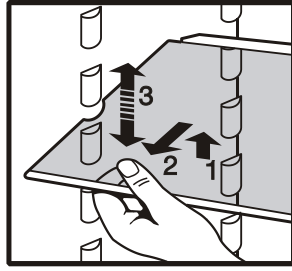

Repositioning the door racks

- Lift door rack vertically (1), lift out to the front and re-insert at a different height, following these steps in the reverse order (2).

- By shifting the **bottle holder F** you can protect the bottles from falling over when opening or closing the door.

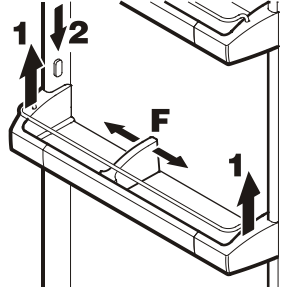

The **sectioned glass shelves** can be moved to make space for tall containers. Place the shelf rails provided, fig. 1, on the supports on the left and right at the desired height.

Insert the glass shelves (1) and (2) as shown in fig. 2. The glass shelf (2) with the raised edge must go at the back. If you need to make space for tall containers, simply slide the **front half** of the sectioned glass shelf carefully underneath the back half, fig. 2.

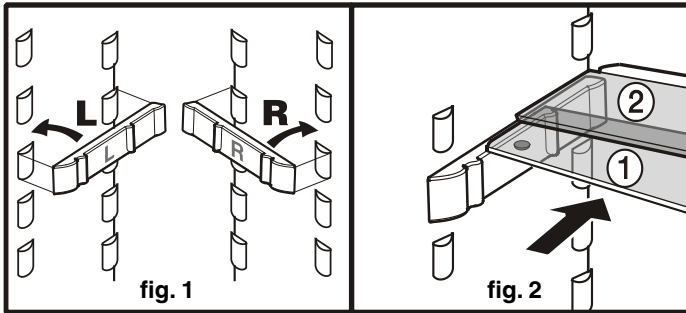

Interior light

This switches off automatically after the door has been opened for approx. 15 minutes. If it does not switch on when the door is opened briefly, but the temperature display is working, the bulb may be defective.

Replacing the bulb:

- **Bulb data:** max. 25 W; current and voltage must agree with the details on the type plate. Bulb fitting: E 14.
- Switch off the appliance. **Disconnect from the mains or remove or unscrew the fuse.**

• Press the light cover together at the top and bottom 1, lift it out and unclip at back 2.

• Replace the bulb. To counteract the friction seal, turn the bulb with slightly more pressure. When inserting the new bulb, ensure that the seal is properly in place in the lamp socket.

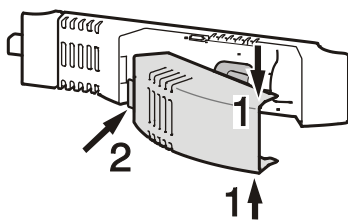

- Clip the back end of the cover in and clip the sides into place.

Cooling

Storage example

- ① butter, cheese
- ② eggs
- ③ bottles, cans, tubes
- ④ frozen food, ice cubes
- ⑤ baked goods, pre-cooked meals, drinks
- ⑥ meat, sausage products, dairy products
- ⑦ fruit, vegetables, salad
- ⑧ salad, fruit, vegetables, drinks

Note

- Food which gives off or absorbs odours and flavours as well as liquids should always be stored covered or in closed containers. High-percentage alcohols should be tightly sealed and stored upright.
- Fruit, vegetables and salad can be stored unpacked in the bins.
- Reusable plastic, metal, aluminium and glass containers can be used for packaging.

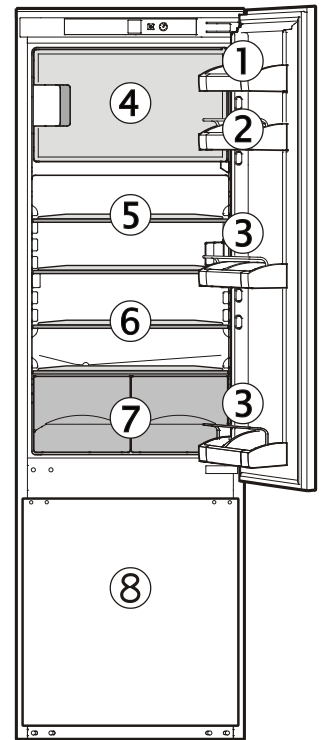

Freezer compartment

You can store frozen food for several months, make ice cubes and freeze fresh food in the freezer compartment at a temperature of -18 °C and lower.

The air temperature in the compartment, measured by thermometer or other instruments, may fluctuate.

Freezing

Fresh food should be frozen to core as quickly as possible. You can freeze up to **2 kg/24 hours**.

- Set the temperature control **T** to a medium to cold setting.
- Wait 24 hours.
- Place the fresh food in the freezer compartment.
- After approx. 24 hours the fresh food will be frozen.
- Now switch back the temperature control to the required setting.

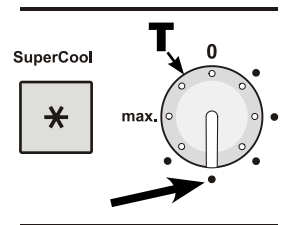

When storing pre-frozen food, the freezer compartment can be filled straight away. It is not necessary to change the temperature setting.

Making ice cubes

Fill the **ice-cube tray** three-quarters full with water and freeze. The ice cubes can be removed from the tray by twisting or by holding upside down for a short time under running water.

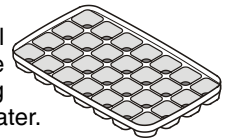

Notes on freezing

- Pack frozen food in standard freezer bags or reuseable plastic, metal or aluminium containers.
- Always write the date and contents on the pack and do not exceed the stated storage time for the food.
- Do not freeze bottles and cans which contain carbonated drinks as they might burst.
- Only take out as much food as is immediately required for thawing. Use food which has been thawed in prepared meals as quickly as possible.

Frozen food can be thawed in the following ways:

- in a fan oven
- in a microwave oven
- at room temperature
- in the refrigerator: the cold given off by the frozen food is used for cooling.

Defrosting

Refrigerator compartment

The refrigerator compartment defrosts automatically. The water that forms on the rear wall drains into a reservoir at the back of the appliance and evaporates automatically through the compressor heat.

Ensure that the water can flow without hindrance through the hole above the vegetable bins.

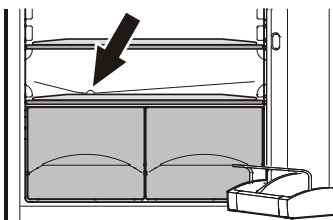

Freezer compartment

After a long period of operation, a layer of frost or ice can build up inside the freezer compartment. This increases energy consumption. You should therefore defrost the freezer compartment regularly.

- Switch the appliance off to defrost. Pull out the mains plug or set the temperature control to "0".
- Wrap the frozen food in paper or blankets and store in a cool place.
- To speed up the defrosting process put a saucepan of hot but not boiling water in the compartment.
- Leave the door of the appliance open while defrosting. After defrosting mop up the remaining water and clean the appliance.

Do not use any mechanical devices or other artificial aids for defrosting other than those recommended by the manufacturer.

Cleaning

Before cleaning always switch off the appliance. Pull out the mains plug or remove/unscrew the fuse.

Clean the inside, equipment parts and outer walls with lukewarm water and a little detergent. Do not use abrasive or acid cleaners or chemical solvents.

Do not use steam cleaners because of the risk of injury and damage.

- Ensure that no cleaning water penetrates into the electrical components or ventilation grille.
- Dry all parts well with a cloth.
- Clean the drain hole in the refrigerator compartment with a thin object, e.g. cotton swab or the like.
- Do not damage or remove the type plate on the inside of the appliance. It is very important for servicing purposes.

Shutting your appliance down

If your appliance is to be shut down for any length of time, switch it off and disconnect the plug or switch off or unscrew the fuse. Clean the appliance and leave the door open in order to prevent unpleasant smells.

The appliance complies with the relevant safety regulations and EC Directives 2004/108/EC and 2006/95/EC.

All types and models are subject to continuous improvement and the manufacturer therefore reserves the right to make modifications to the shape, equipment and technology.

Malfunctions

You may be able to rectify the following faults by checking the possible causes yourself:

• Appliance does not function:

- Is the appliance switched on?
- Is the plug correctly fitted in the mains socket?
- Is the socket fuse intact?

• Loud running noise:

- Is the appliance set up firmly on the floor?
- Does the appliance cause nearby items of furniture or objects to vibrate? Please note that noises caused by the refrigerant circuit cannot be avoided.

• The temperature is not low enough:

- Is the temperature setting correct (see "Setting the temperature")?
- Have excessive amounts of fresh food been placed in the appliance?
- Does the separately installed thermometer show the correct reading?
- Is the ventilation system working properly?
- Is the appliance set up too close to a heat source?

• The inside of the appliance may feel warm in places

- That is quite normal. The dissipated heat is necessary for normal operation of the appliance.

If none of the above causes apply and you cannot rectify the fault yourself, contact the nearest customer service department stating the type of appliance ①, service number ② and appliance number ③ as indicated on the type plate. The type plate is located in the refrigerator compartment on the left-hand side.

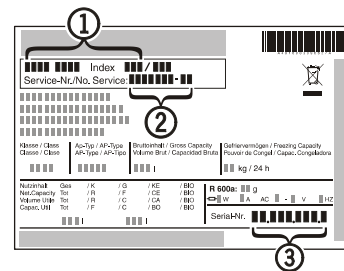

Installation dimensions (mm)

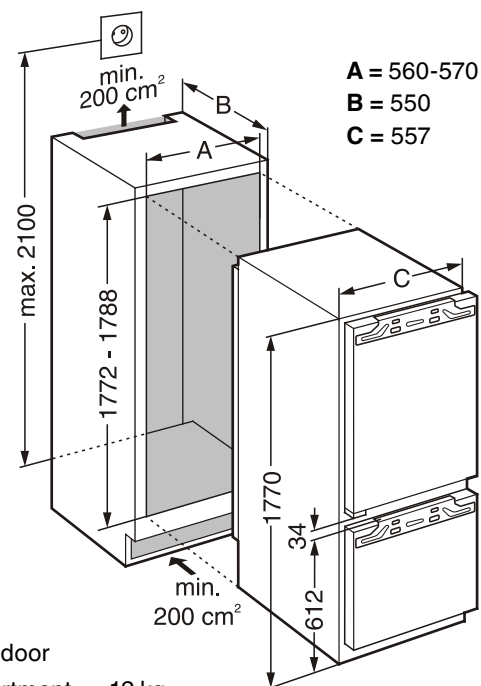

Changing over door hinges

1. Lift off covers ③ .
2. Loosen attachment screws ① on the appliance.
3. Remove the door.
4. Replace all attachment screws ① on the other side and screw in a little way.
5. Unscrew door attachment screws ② and transfer the hinges to the diagonally opposite corner.
6. Suspend the appliance door on the screws ① inserted previously and tighten the screws.
7. Cover all open attachment holes with covers ③ .

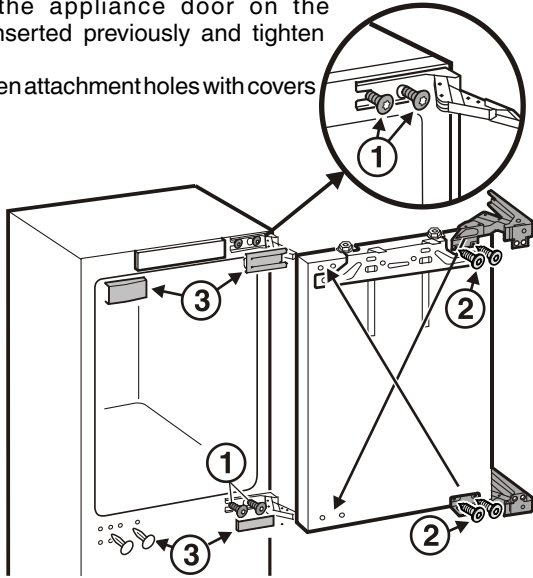

Changing the compartment door

- At hinge ① fold away the cover. Unscrew hinge ① and remove the compartment door with the hinge.
- Unscrew the closure ② .
- Close the holes with the plugs ③ .
- Rotate the door and closure by 180° and replace on the other side: Insert the compartment door at the top, put the hinge ① in place at the bottom, screw down again and close the cover.

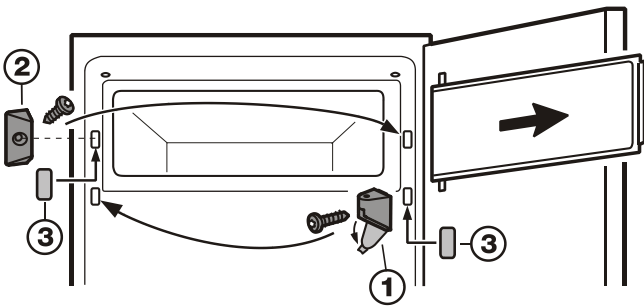

Pull off film and stick sealing strip to handle side of appliance, shortening to the height of the recess if necessary.

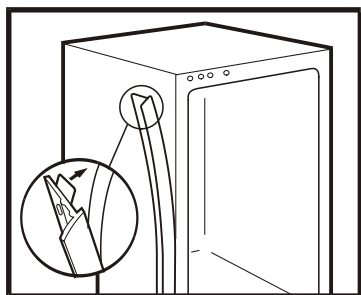

Installing in a kitchen unit

- For 16 mm unit wall (568 mm recess):
- Clip spacers ⑩ onto the hinges.

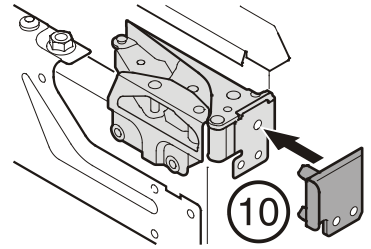

- Fit the equaliser trim ⑨ in the recesses on the retainer.

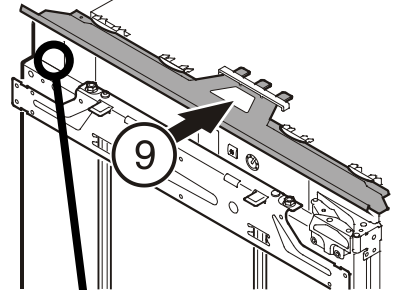

- Remove cover ⑪ .
- Screw on the attachment brackets ⑫ top and bottom.
- Clip the stop brackets ⑬ onto the attachment brackets top and bottom.

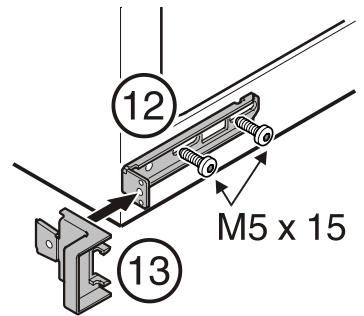
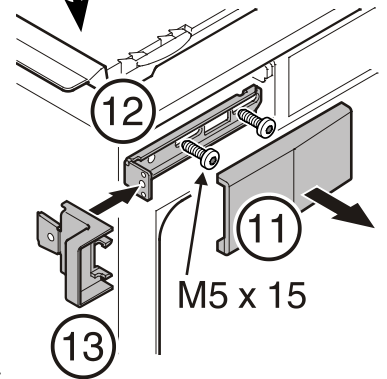

- Screw the attachment bracket ⑭ into the predrilled holes on the appliance door using the hexagonal screw.

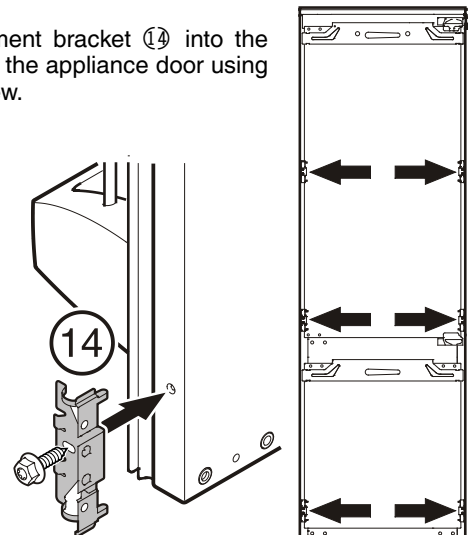

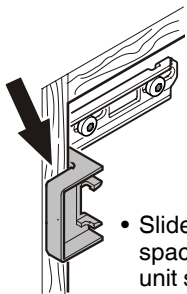

- Slide appliance into the recess until the spacers make contact with the kitchen unit side panels.

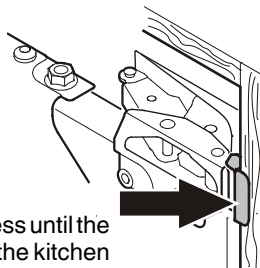

- Use the adjustable feet to align the appliance to an upright position, using the spanner supplied.

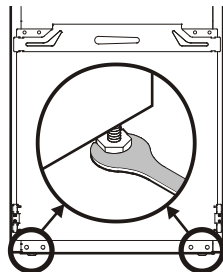

Fasten the appliance in the recess:

- through the hinges at the side.

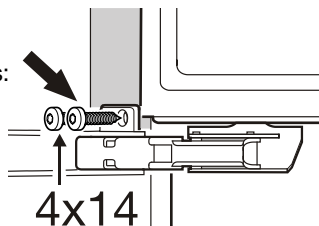

Fasten the appliance in the recess:

- through the top and bottom attachment brackets at the side.
- Snap off and remove the front part of the stop bracket 13. This part will be needed for covering the top bracket in the next step.

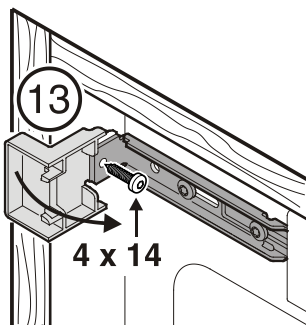

- Attach the top left covers.

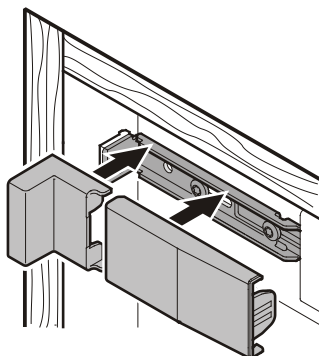

- Snap off and remove the front part of the bottom stop bracket. This part is no longer needed.
- Click cover 15 into place.

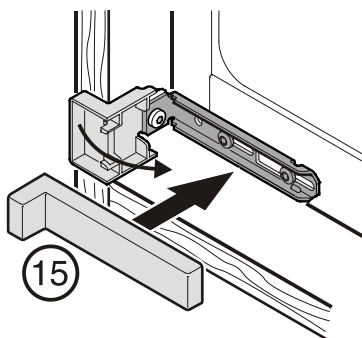

Fitting a unit door

1. Lift the fitting aids out to the top, turn round and insert into the adjacent openings.

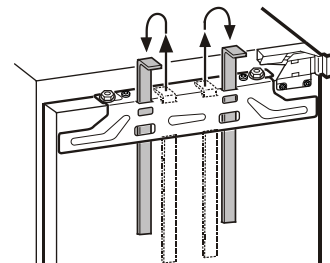

2. Slide the fitting aids 4 up level with the unit door: underside of stop edge of fitting aid = upper edge of unit door.
3. Unscrew the counternuts 3.

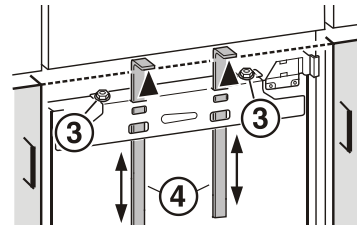

4. Suspend the attachment strut 1 on the unit door.
5. Fasten the attachment strut 1.
6. Lift the fitting aids 4 out to the top, turn round and insert into the adjacent openings.

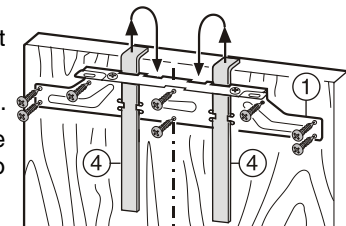

7. Suspend the unit door on the door of the appliance/adjusting pins 2. Screw the counternuts 3 loosely onto the adjusting pins.

8. Align the unit door flush with the surrounding unit fronts: align laterally X by sliding in the corresponding direction, adjust height Y and lateral tilt with the adjusting pins 2 with a screwdriver. Tighten counternuts 3.
9. Adjust the depth of the unit door Z: loosen the screws 7.

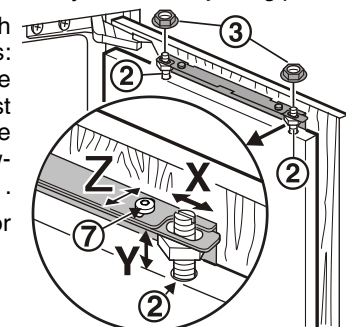

10. Screw the appliance door onto the unit door through the attachment brackets.

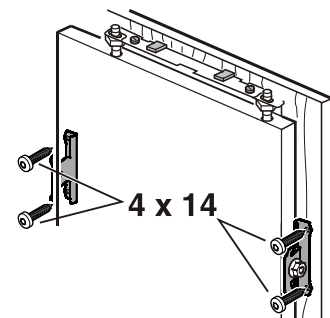

11. Attach all the covers 15, 16, 17.

